

# DTC/DTH SERIES

## LIGHT COMMERCIAL PACKAGED HEATING AND COOLING UNIT

3 TO 5 TON

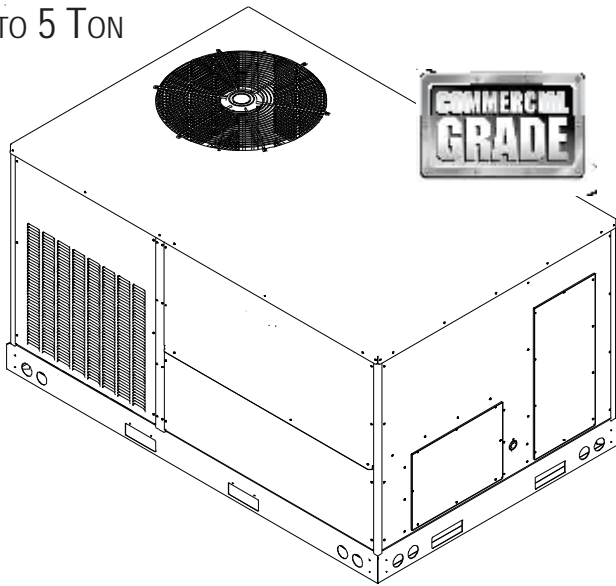

### Index

- Replacement Parts ..... 2
- Safety Instructions ..... 2
- General Information ..... 2
- Unit Location ..... 3
- Clearances ..... 4
- Roof Curb Post-Installation Checks ..... 5
- Roof Top Duct Connections ..... 5
- Rigging Details ..... 5
- Electrical Wiring ..... 6
- Circulating Air and Filters ..... 8
- Condensate Drain Connection ..... 8
- Startup, Adjustments, and Checks ..... 9
- Air Flow Adjustments ..... 10
- Heat Pump Operation ..... 11
- Maintenance ..... 12
- Troubleshooting ..... 13
- Appendix A Blower Performance Tables ..... 14
  - Direct Drive ..... 14
    - DTC/DTH036 Standard Down Shot and Horizontal ..... 14
    - DTC/DTH048 Standard Horizontal ..... 15
    - DTC/DTH060 Standard Down Shot ..... 16
    - DTC/DTH060 Standard Horizontal ..... 17
- Appendix B Electrical Data ..... 18
- Appendix B Electrical Data ..... 19
- Appendix C Unit Dimensions ..... 20
- Wiring Diagrams ..... 21
- Wiring Diagrams for Models With DDC Controls ..... 25
- Startup Checklist ..... 34



**ATTENTION INSTALLING PERSONNEL:**  
 Prior to installation, thoroughly familiarize yourself with this Installation Manual. Observe all safety warnings. During installation or repair, caution is to be observed.

It is your responsibility to install the product safely and to educate the customer on its safe use.

**! RECOGNIZE THIS SYMBOL  
 AS A SAFETY PRECAUTION.**

These installation instructions cover the **outdoor** installation of single package heating and cooling units. See the Specification Sheet applicable to your model for information regarding accessories.

**\*NOTE:** Please contact your distributor or our website for the applicable Specification Sheet referred to in this manual.

Our continuing commitment to quality products may mean a change in specifications without notice.

© 2015 - 2017 **DAIKIN COMPANY, L.P.**  
 5151 San Felipe St., Suite 500, Houston, TX 77056  
[www.daikinac.com](http://www.daikinac.com)



## REPLACEMENT PARTS

### ORDERING PARTS

When reporting shortages or damages, or ordering repair parts, give the complete unit model and serial numbers as stamped on the unit's nameplate.

Replacement parts for this appliance are available through your contractor or local distributor. For the location of your nearest distributor, consult the white business pages, the yellow page section of the local telephone book or contact:

EQUIPMENT SUPPORT  
DAIKIN NORTH AMERICA LLC  
19001 KERMIER ROAD  
WALLER, TEXAS 77484  
855-770-5678

### SAFETY INSTRUCTIONS

#### TO THE INSTALLER

Before installing this unit, please read this manual to familiarize yourself on the specific items which must be adhered to, including maximum external static pressure to unit, air temperature rise, minimum or maximum CFM and motor speed connections.

Keep this literature in a safe place for future reference.

#### CAUTION

**SHEET METAL PARTS, SCREWS, CLIPS AND SIMILAR ITEMS INHERENTLY HAVE SHARP EDGES, AND IT IS NECESSARY THAT THE INSTALLER AND SERVICE PERSONNEL EXERCISE CAUTION.**

#### WARNING

**DO NOT CONNECT TO OR USE ANY DEVICE THAT IS NOT DESIGN CERTIFIED BY THE MANUFACTURER FOR USE WITH THIS UNIT. SERIOUS PROPERTY DAMAGE, PERSONAL INJURY, REDUCED UNIT PERFORMANCE AND/OR HAZARDOUS CONDITIONS MAY RESULT FROM THE USE OF SUCH NON-APPROVED DEVICES.**

#### WARNING

**THIS PRODUCT CONTAINS OR PRODUCES A CHEMICAL OR CHEMICALS WHICH MAY CAUSE SERIOUS ILLNESS OR DEATH AND WHICH ARE KNOWN TO THE STATE OF CALIFORNIA TO CAUSE CANCER, BIRTH DEFECTS OR OTHER REPRODUCTIVE HARM.**

#### WARNING

**TO AVOID PROPERTY DAMAGE, PERSONAL INJURY OR DEATH, DO NOT USE THIS UNIT IF ANY PART HAS BEEN UNDER WATER. IMMEDIATELY CALL A QUALIFIED SERVICE TECHNICIAN TO INSPECT THE FURNACE AND TO REPLACE ANY PART OF THE CONTROL SYSTEM AND ANY GAS CONTROL HAVING BEEN UNDER WATER.**

#### WARNING

**THIS UNIT MUST NOT BE USED AS A "CONSTRUCTION HEATER" DURING THE FINISHING PHASES OF CONSTRUCTION ON A NEW STRUCTURE. THIS TYPE OF USE MAY RESULT IN PREMATURE FAILURE OF THE UNIT DUE TO EXTREMELY LOW RETURN AIR TEMPERATURES AND EXPOSURE TO CORROSIVE OR VERY DIRTY ATMOSPHERES.**

#### WARNING

**HIGH VOLTAGE!**  
**DISCONNECT ALL POWER BEFORE SERVICING OR INSTALLING THIS UNIT. MULTIPLE POWER SOURCES MAY BE PRESENT. FAILURE TO DO SO MAY CAUSE PROPERTY DAMAGE, PERSONAL INJURY OR DEATH.**



#### WARNING

**TO PREVENT THE RISK OF PROPERTY DAMAGE, PERSONAL INJURY, OR DEATH, DO NOT STORE COMBUSTIBLE MATERIALS OR USE GASOLINE OR OTHER FLAMMABLE LIQUIDS OR VAPORS IN THE VICINITY OF THIS APPLIANCE.**

#### WARNING

**ONLY PERSONNEL THAT HAVE BEEN TRAINED TO INSTALL, ADJUST, SERVICE OR REPAIR (HEREINAFTER, "SERVICE") THE EQUIPMENT SPECIFIED IN THIS MANUAL SHOULD SERVICE THE EQUIPMENT. THE MANUFACTURER WILL NOT BE RESPONSIBLE FOR ANY INJURY OR PROPERTY DAMAGE ARISING FROM IMPROPER SERVICE OR SERVICE PROCEDURES. IF YOU SERVICE THIS UNIT, YOU ASSUME RESPONSIBILITY FOR ANY INJURY OR PROPERTY DAMAGE WHICH MAY RESULT. IN ADDITION, IN JURISDICTIONS THAT REQUIRE ONE OR MORE LICENSES TO SERVICE THE EQUIPMENT SPECIFIED IN THIS MANUAL, ONLY LICENSED PERSONNEL SHOULD SERVICE THE EQUIPMENT. IMPROPER INSTALLATION, ADJUSTMENT, SERVICING OR REPAIR OF THE EQUIPMENT SPECIFIED IN THIS MANUAL, OR ATTEMPTING TO INSTALL, ADJUST, SERVICE OR REPAIR THE EQUIPMENT SPECIFIED IN THIS MANUAL WITHOUT PROPER TRAINING MAY RESULT IN PRODUCT DAMAGE, PROPERTY DAMAGE, PERSONAL INJURY OR DEATH.**

## GENERAL INFORMATION

#### WARNING

**TO PREVENT PROPERTY DAMAGE PERSONAL INJURY OR DEATH, DUE TO FIRE, EXPLOSIONS, SMOKE, SOOT, CONDENSATION, ELECTRIC SHOCK OR CARBON MONOXIDE, THIS UNIT MUST BE PROPERLY INSTALLED, REPAIRED, OPERATED, AND MAINTAINED.**

*This unit is approved for outdoor installation ONLY.* Rated performance is achieved after 72 hours of operation. Rated performance is delivered at the specified airflow. See product specification sheet for light commercial models. Specification sheets can be found at [www.daikinac.com](http://www.daikinac.com) for Daikin brand products. Within the website, please select the commercial products menu and then select the submenu for the type of product to be installed, such as air conditioners or heat pumps, to access a list of product pages that each contain links to that model's specification sheet.

To assure that your unit operates safely and efficiently, it must be installed, operated, and maintained in accordance with these installation and operating instructions, all local building codes and ordinances.

## EPA REGULATIONS

**IMPORTANT: THE UNITED STATES ENVIRONMENTAL PROTECTION AGENCY (EPA) HAS ISSUED VARIOUS REGULATIONS REGARDING THE INTRODUCTION AND DISPOSAL OF REFRIGERANTS IN THIS UNIT. FAILURE TO FOLLOW THESE REGULATIONS MAY HARM THE ENVIRONMENT AND CAN LEAD TO THE IMPOSITION OF SUBSTANTIAL FINES. BECAUSE REGULATIONS MAY VARY DUE TO PASSAGE OF NEW LAWS, WE SUGGEST A CERTIFIED TECHNICIAN PERFORM ANY WORK DONE ON THIS UNIT. SHOULD YOU HAVE ANY QUESTIONS PLEASE CONTACT THE LOCAL OFFICE OF THE EPA.**

## NATIONAL CODES

This product is designed and manufactured to permit installation in accordance with National Codes. It is the installer's responsibility to install the product in accordance with National Codes and/or prevailing local codes and regulations.

The heating and cooling capacities of the unit should be greater than or equal to the design heating and cooling loads of the area to be conditioned. The loads should be calculated by an approved method or in accordance with ASHRAE Guide or Manual J - Load Calculations published by the Air Conditioning Contractors of America.

Obtain from:

American National Standards Institute  
25 West 43<sup>rd</sup> Street, 4<sup>th</sup> Floor  
New York, NY 10018

System design and installation should also, where applicable, follow information presented in accepted industry guides such as the ASHRAE Handbooks. The manufacturer assumes no responsibility for equipment installed in violation of any code or regulation. The mechanical installation of the packaged roof top units consists of making final connections between the unit and building services; supply and return duct connections; and drain connections (if required). The internal systems of the unit are completely factory-installed and tested prior to shipment.

Units are generally installed on a steel roof mounting curb assembly which has been shipped to the job site for installation on the roof structure prior to the arrival of the unit. The model number shown on the unit's identification plate identifies the various components of the unit such as refrigeration tonnage, heating input and voltage.

Carefully inspect the unit for damage including damage to the cabinetry. Any bolts or screws which may have loosened in transit must be re-tightened. In the event of damage, the receiver should:

1. Make notation on delivery receipt of any visible damage to shipment or container.
2. Notify carrier promptly and request an inspection.
3. In case of concealed damage, carrier should be notified as soon as possible-preferably within 5 days.
4. File the claim with the following supporting documents:
  - a. Original Bill of Lading, certified copy, or indemnity bond.
  - b. Original paid freight bill or indemnity in lieu thereof.
  - c. Original invoice or certified copy thereof, showing trade and other discounts or reductions.

- d. Copy of the inspection report issued by carrier representative at the time damage is reported to the carrier. The carrier is responsible for making prompt inspection of damage and for a thorough investigation of each claim. The distributor or manufacturer will not accept claims from dealers for transportation damage.

**NOTE:** When inspecting the unit for transportation damage, remove all packaging materials. Recycle or dispose of the packaging material according to local codes.

## PRE-INSTALLATION CHECKS

Carefully read all instructions for the installation prior to installing unit. Ensure each step or procedure is understood and any special considerations are taken into account before starting installation. Assemble all tools, hardware and supplies needed to complete the installation. Some items may need to be purchased locally.

## UNIT LOCATION



### WARNING

**TO PREVENT POSSIBLE EQUIPMENT DAMAGE, PROPERTY DAMAGE, PERSONAL INJURY OR DEATH, THE FOLLOWING BULLET POINTS MUST BE OBSERVED WHEN INSTALLING THE UNIT.**

**IMPORTANT NOTE:** Remove wood shipping rails prior to installation of the unit.

## ALL INSTALLATIONS:

**IMPORTANT NOTE:** *Unit should be energized 24 hours prior to compressor start up to ensure crankcase heater has sufficiently warmed the compressors. Compressor damage may occur if this step is not followed.*

**NOTE:** Appliance is shipped from factory for vertical duct application.

Proper installation of the unit ensures trouble-free operation. Improper installation can result in problems ranging from noisy operation to property or equipment damages, dangerous conditions that could result in injury or personal property damage. Give this booklet to the user and explain its provisions. The user should retain these instructions for future reference.

- For proper operation and condensate drainage, the unit must be mounted level.
- Do not locate the unit in an area where the outdoor air will be frequently contaminated by compounds containing chlorine or fluorine. Common sources of such compounds include swimming pool chemicals and chlorine bleaches, paint stripper, adhesives, paints, varnishes, sealers, waxes (which are not yet dried) and solvents used during construction and remodeling. Various commercial and industrial processes may also be sources of chlorine/fluorine compounds.

- To avoid possible illness or death of the building occupants, do NOT locate outside air intake device (economizer, manual fresh air intake, motorized fresh air intake) too close to an exhaust outlet, gas vent termination, or plumbing vent outlet. For specific distances required, consult local codes.
- Allow minimum clearances from the enclosure for fire protection, proper operation, and service access (see Unit Clearances). These clearances must be permanently maintained.
- When the unit is heating, the temperature of the return air entering the unit must be a minimum of 55°F.

#### GROUND LEVEL INSTALLATIONS ONLY:

- When the unit is installed on the ground adjacent to the building, a level concrete (or equal) base is recommended. Prepare a base that is 3" larger than the package unit footprint and a minimum of 3" thick.
- The base should also be located where no runoff of water from higher ground can collect in the unit.

#### ROOF TOP INSTALLATIONS ONLY:

- To avoid possible property damage or personal injury, the roof must have sufficient structural strength to carry the weight of the unit(s) and snow or water loads as required by local codes. Consult a structural engineer to determine the weight capabilities of the roof.
- The unit may be installed directly on wood floors or on Class A, Class B, or Class C roof covering material.
- To avoid possible personal injury, a safe, flat surface for service personnel should be provided.
- Adequate clearances from the unit to any adjacent public walkways, adjacent buildings, building openings or openable windows must be maintained in accordance with National Codes.

#### UNIT PRECAUTIONS

- Do not stand or walk on the unit.
- Do not drill holes anywhere in panels or in the base frame of the unit (except where indicated). Unit access panels provide structural support.
- Do not remove any access panels until unit has been installed on roof curb or field supplied structure.
- Do not roll unit across finished roof without prior approval of owner or architect.
- Do not skid or slide on any surface as this may damage unit base. The unit must be stored on a flat, level surface. Protect the condenser coil because it is easily damaged.

#### ROOF CURB INSTALLATIONS ONLY:

Curb installations must comply with local codes and should be done in accordance with the established guidelines of the National Roofing Contractors Association.

Proper unit installation requires that the roof curb be firmly and permanently attached to the roof structure. Check for adequate fastening method prior to setting the unit on the curb.

Full perimeter roof curbs are available from the factory and are shipped unassembled. Field assembly, squaring, leveling and mounting on the roof structure are the responsibility of the installing contractor. All required hardware necessary for the assembly of the sheet metal curb is included in the curb accessory.

### WARNING

**TO PREVENT POSSIBLE EQUIPMENT DAMAGE, PROPERTY DAMAGE, PERSONAL INJURY OR DEATH, THE FOLLOWING BULLET POINTS MUST BE OBSERVED WHEN INSTALLING THE UNIT.**

- Sufficient structural support must be determined prior to locating and mounting the curb and package unit.
- Ductwork must be constructed using industry guidelines. The duct work must be placed into the roof curb before mounting the package unit. Our full perimeter curbs include duct connection frames to be assembled with the curb. Cantilevered type curbs are not available from the factory.
- Curb insulation, cant strips, flashing and general roofing material are furnished by the contractor.

The curbs must be supported on parallel sides by roof members. The roof members must not penetrate supply and return duct opening areas as damage to the unit might occur.

**NOTE:** The unit and curb accessories are designed to allow vertical duct installation before unit placement. Duct installation after unit placement is not recommended.

### CAUTION

**ALL CURBS LOOK SIMILAR. TO AVOID INCORRECT CURB POSITIONING, CHECK JOB PLANS CAREFULLY AND VERIFY MARKINGS ON CURB ASSEMBLY. INSTRUCTIONS MAY VARY IN CURB STYLES AND SUPERSEDES INFORMATION SHOWN.**

See the manual shipped with the roof curb for assembly and installation instructions.

#### CLEARANCES

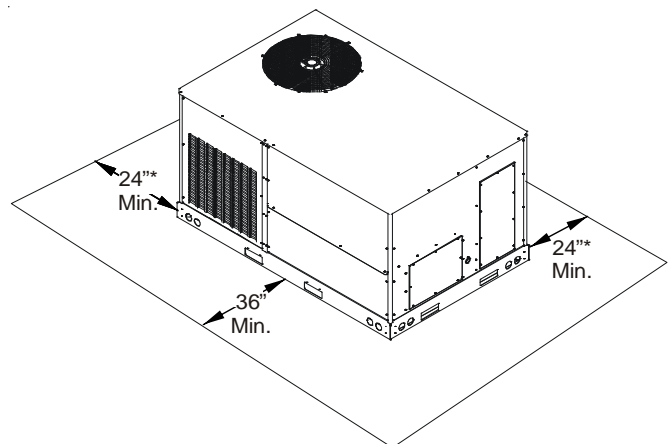

UNIT CLEARANCES

*\*In situations that have multiple units, a 48" minimum clearance is required between the condenser coils.*

Adequate clearance around the unit should be kept for safety, service, maintenance, and proper unit operation. A total clearance of 75" on the main control panel side of the unit is recommended to facilitate possible fan shaft, coil, and electric heat. A clearance of 48" is recommended on all other sides of the unit to facilitate possible compressor removal, to allow service access and to insure proper ventilation and condenser airflow. The unit must not be installed beneath any obstruction. The unit should be installed remote from all building exhausts to inhibit ingestion of exhaust air into the unit fresh air intake.

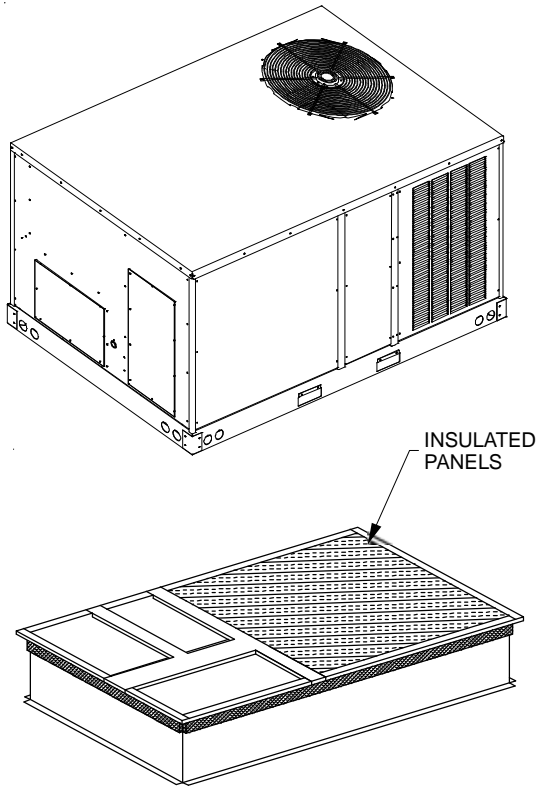

ROOF CURB INSTALLATION

### ROOF CURB POST-INSTALLATION CHECKS

After installation, check the top of the curb, duct connection frame and duct flanges to make sure gasket has been applied properly. Gasket should be firmly applied to the top of the curb perimeter, duct flanges and any exposed duct connection frame. If gasket is loose, re-apply using strong weather resistant adhesive.

#### PROTRUSION

Inspect curb to ensure that none of the utility services (electric) routed through the curb protrude above the curb.



**CAUTION**

**IF PROTRUSIONS EXIST, DO NO ATTEMPT TO SET UNIT ON CURB.**

### ROOF TOP DUCT CONNECTIONS

Install all duct connections on the unit before placing the unit on rooftop.

#### HORIZONTAL DISCHARGE

Refer to IOD-7006 included in the literature pack for installing horizontal duct covers.

Flexible duct connectors between the unit and ducts are recommended. Insulate and weatherproof all external ductwork and joints as required and in accordance with local codes.

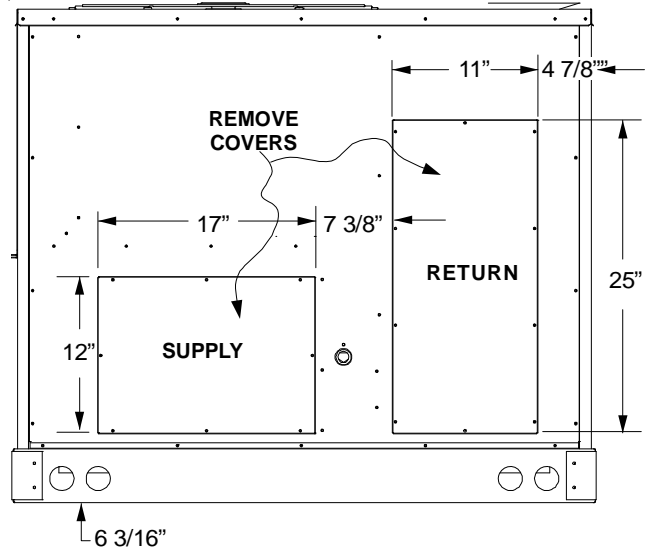

HORIZONTAL DISCHARGE DUCT CONNECTIONS

### RIGGING DETAILS



**WARNING**

**TO PREVENT PROPERTY DAMAGE, THE UNIT SHOULD REMAIN IN AN UPRIGHT POSITION DURING ALL RIGGING AND MOVING OPERATIONS. TO FACILITATE LIFTING AND MOVING WHEN A CRANE IS USED, PLACE THE UNIT IN AN ADEQUATE CABLE SLING.**



**CAUTION**

**IF UNITS ARE LIFTED TWO AT A TIME, THE FORK HOLES ON THE CONDENSER END OF THE UNIT MUST NOT BE USED. MINIMUM FORK LENGTH IS 42" TO PREVENT DAMAGE TO THE UNIT; HOWEVER, 48" IS RECOMMENDED.**

Provisions for forks have been included in the unit base frame. No other fork locations are approved.



**WARNING**

**TO PREVENT POSSIBLE EQUIPMENT DAMAGE, PROPERTY DAMAGE, PERSONAL INJURY OR DEATH, THE FOLLOWING BULLET POINTS MUST BE OBSERVED WHEN INSTALLING THE UNIT.**

- Unit must be lifted by the four lifting holes located at the base frame corners.
- Lifting cables should be attached to the unit with shackles.
- The distance between the crane hook and the top of the unit must not be less than 60".
- Two spreader bars must span over the unit to prevent damage to the cabinet by the lift cables. Spreader bars must be of sufficient length so that cables do not come in contact with the unit during transport. Remove wood struts mounted beneath unit base frame before setting unit on roof curb. These struts are intended to protect unit base frame from fork lift damage. Removal is accomplished by extracting the sheet metal retainers and pulling the struts through the base of the unit. Refer to rigging label on the unit.

**Important:** If using bottom discharge with roof curb, ductwork should be attached to the curb prior to installing the unit. Ductwork dimensions are shown in Roof Curb Installation Instructions.

Refer to the Roof Curb Installation Instructions for proper curb installation. Curbing must be installed in compliance with the National Roofing Contractors Association Manual.

Lower unit carefully onto roof mounting curb. While rigging unit, center of gravity will cause condenser end to be lower than supply air end.

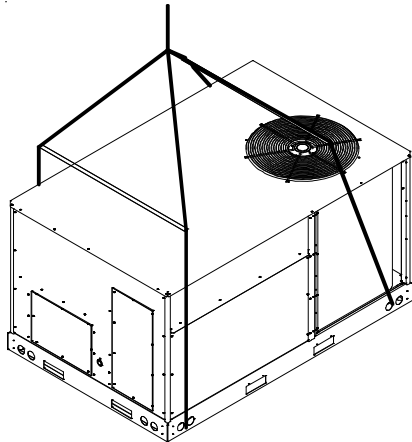

To assist in determining rigging requirements, unit weights are shown as follows:

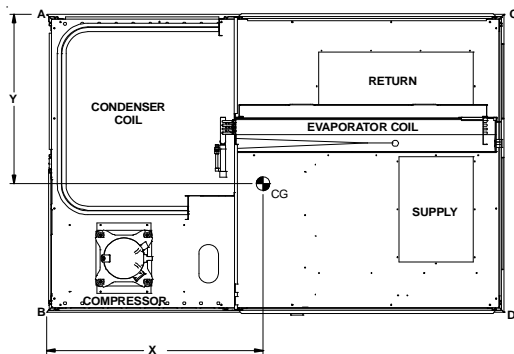

CORNER & CENTER OF GRAVITY LOCATIONS

A* Model	X (in)	Y (in)	Shipping Weight (lbs)	Operating Weight (lbs)	Corner Weights ( lbs )			
					A	B	C	D
DTC036*	35	27	571	546	122	165	111	146
DTC048*	35	27	590	564	131	167	118	148
DTC060*	35	27	635	610	143	178	126	163
DTH036*	34	28	581	556	130	175	105	146
DTH048*	34	28	600	574	131	181	111	151
DTH060*	34	28	645	620	141	193	121	165

**CAUTION**

**TO PREVENT SEVERE DAMAGE TO THE BOTTOM OF THE UNIT, DO NOT FORK LIFT UNIT AFTER WOOD STRUTS HAVE BEEN REMOVED.**

Bring condenser end of unit into alignment with the curb. With condenser end of the unit resting on curb member and using curb as a fulcrum, lower opposite end of the unit until entire unit is seated on the curb. When a rectangular cantilever curb is used, care should be taken to center the unit. Check for proper alignment and orientation of supply and return openings with duct.

**RIGGING REMOVAL**

**CAUTION**

**TO PREVENT DAMAGE TO THE UNIT, DO NOT ALLOW CRANE HOOKS AND SPREADER BARS TO REST ON THE ROOF OF THE UNIT.**

Remove spreader bars, lifting cables and other rigging equipment.

**ELECTRICAL WIRING**

**WARNING**

**HIGH VOLTAGE!**  
DISCONNECT ALL POWER BEFORE SERVICING OR INSTALLING THIS UNIT. MULTIPLE POWER SOURCES MAY BE PRESENT. FAILURE TO DO SO MAY CAUSE PROPERTY DAMAGE, PERSONAL INJURY OR DEATH.



**WARNING**

**HIGH VOLTAGE!**  
TO AVOID PERSONAL INJURY OR DEATH DUE TO ELECTRICAL SHOCK, DO NOT TAMPER WITH FACTORY WIRING. THE INTERNAL POWER AND CONTROL WIRING OF THESE UNITS ARE FACTORY-INSTALLED AND HAVE BEEN THOROUGHLY TESTED PRIOR TO SHIPMENT. CONTACT YOUR LOCAL REPRESENTATIVE IF ASSISTANCE IS REQUIRED.



**CAUTION**

**TO PREVENT DAMAGE TO THE WIRING, PROTECT WIRING FROM SHARP EDGES. FOLLOW NATIONAL ELECTRICAL CODE AND ALL LOCAL CODES AND ORDINANCES. DO NOT ROUTE WIRES THROUGH REMOVABLE ACCESS PANELS.**

**CAUTION**

**CONDUIT AND FITTINGS MUST BE WEATHER-TIGHT TO PREVENT WATER ENTRY INTO THE BUILDING.**

For unit protection, use a fuse or HACR circuit breaker that is in excess of the circuit ampacity, but less than or equal to the maximum overcurrent protection device. **DO NOT EXCEED THE MAXIMUM OVERCURRENT DEVICE SIZE SHOWN ON UNIT DATA PLATE.**

All line voltage connections must be made through weatherproof fittings. All exterior power supply and ground wiring must be in approved weatherproof conduit.

The main power supply wiring to the unit and low voltage wiring to accessory controls must be done in accordance with these instructions, the latest edition of the National Electrical Code (ANSI/NFPA 70), and all local codes and ordinances.

The unit is factory wired for the voltage shown on the unit's data plate. Refer to model nomenclature in Appendix B for voltage requirement for your unit.

**NOTE:** If supply voltage is 208V, lead on primary of transformer(s) must be moved from the 230V to the 208V tap. Refer to wiring diagram on unit for details.

Main power wiring should be sized for the minimum circuit ampacity shown on the unit's data plate. Size wires in accordance with the ampacity tables in Article 310 of the National Electrical Code. If long wires are required, it may be necessary to increase the wire size to prevent excessive voltage drop. Wires should be sized for a maximum of 3% voltage drop.

**CAUTION**

**TO AVOID PROPERTY DAMAGE OR PERSONAL INJURY DUE TO FIRE, USE ONLY COPPER CONDUCTORS.**

**CAUTION**

**LABEL ALL WIRES PRIOR TO DISCONNECTION WHEN SERVICING CONTROLS. WIRING ERRORS CAN CAUSE IMPROPER AND DANGEROUS OPERATION. VERIFY PROPER OPERATION AFTER SERVICING.**

**NOTE:** A weather-tight disconnect switch, properly sized for the unit total load, must be field or factory installed. An external field supplied disconnect may be mounted on the exterior panel.

Ensure the data plate is not covered by the field-supplied disconnect switch.

- Some disconnect switches are not fused. Protect the power leads at the point of distribution in accordance with the unit's data plate.
- The unit must be electrically grounded in accordance with local codes or, in the absence of local codes, with the latest edition of the National Electrical Code (ANSI-NFPA 70). A ground lug is provided for this purpose. Size grounding conductor in accordance with Table 250-95 of the National Electrical Code. Do not use the ground lug for connecting a neutral conductor.

- Remove plug in panel located at the condenser end of unit and route conduit to control box. Remove plug in control box and connect power wiring to the contactor closest to the entrance. If Single Point kit is used, refer to Installation Instructions supplied with kit.

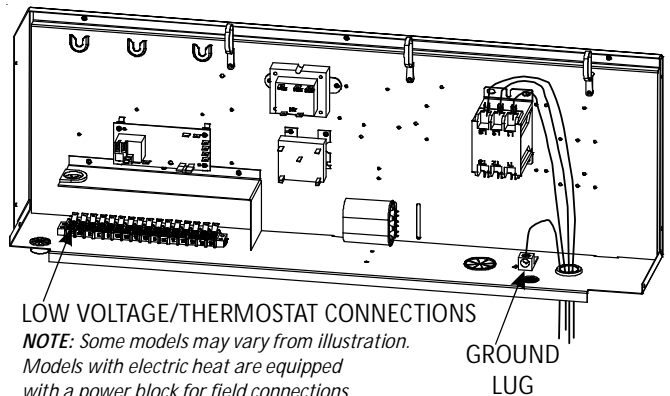
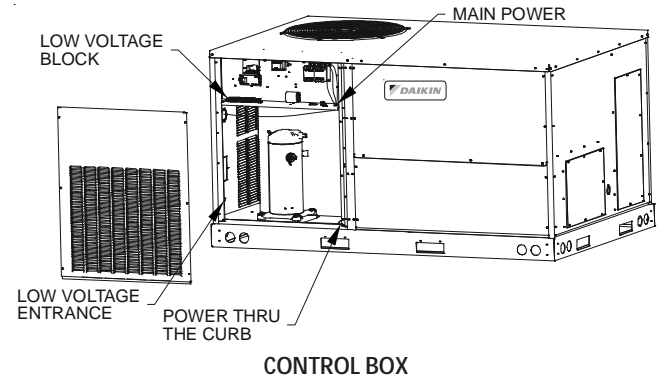

**CONTROL BOX CONNECTIONS**

**NOTE:** Depending on the options installed, the location of the components may vary in some models.

**WARNING**

**FAILURE OF UNIT DUE TO OPERATION ON IMPROPER LINE VOLTAGE OR WITH EXCESSIVE PHASE UNBALANCE CONSTITUTES PRODUCT ABUSE AND IS NOT COVERED BY THE WARRANTY. IT MAY CAUSE SEVERE DAMAGE TO THE UNIT ELECTRICAL COMPONENTS.**

*Areas Without Convenience Outlet*

It is recommended that an independent 115V power source be brought to the vicinity of the roof top unit for portable lights and tools used by the service mechanic.

**NOTE:** Refer to local codes for requirements. These outlets can also be factory installed.

**UNITS INSTALLED ON ROOF TOPS**

Main power and low voltage wiring may enter the unit through the condenser end or through the roof curb. Install conduit connectors at the desired entrance locations. External connectors must be weatherproof. All holes in the unit base must be sealed (including those around conduit nuts) to prevent water leakage into building. All required conduit and fittings are to be field supplied.

Supply voltage to roof top unit must not vary by more than 10% of the value indicated on the unit's data plate. Phase voltage unbalance must not exceed 2%. Contact your local power company for correction of improper voltage or phase unbalance.

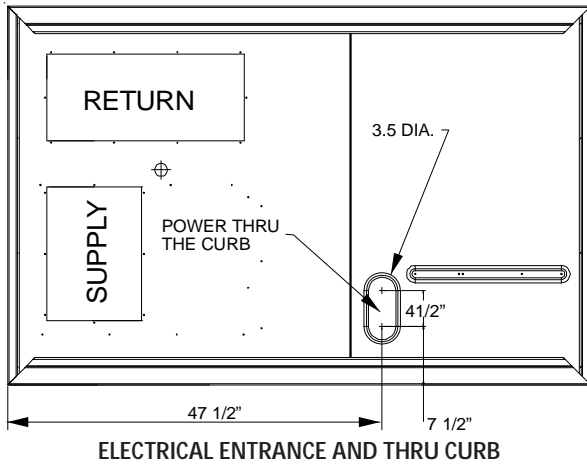
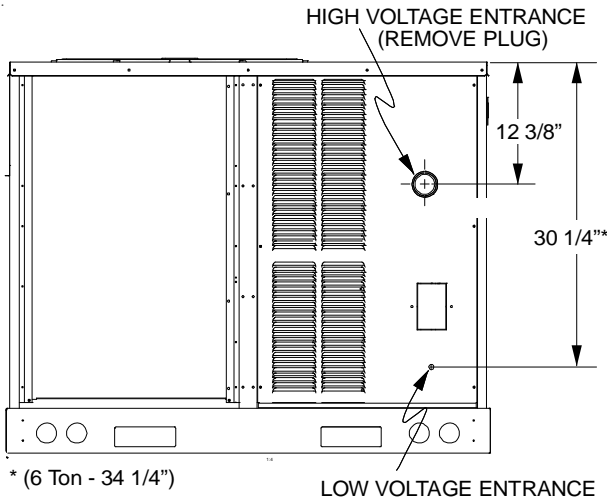

### LOW VOLTAGE CONTROL WIRING

1. A 24V thermostat must be installed for unit operation. It may be purchased with the unit or field-supplied. Thermostats may be programmable or electromechanical as required.
2. Locate thermostat or remote sensor in the conditioned space where it will sense average temperature. Do not locate the device where it may be directly exposed to supply air, sunlight or other sources of heat. Follow installation instructions packaged with the thermostat.
3. Use #18 AWG wire for 24V control wiring runs not exceeding 75 feet. Use #16 AWG wire for 24V control wiring runs not exceeding 125 feet. Use #14 AWG wire for 24V control wiring runs not exceeding 200 feet. Low voltage wiring may be National Electrical Code (NEC) Class 2 where permitted by local codes.
4. Route thermostat wires from sub-base terminals to the unit. Control wiring should enter through the condenser panel opening indicated in "Electrical Entrance" figure. Connect thermostat and any accessory wiring to low voltage terminal block TB1 in the main control box.

**NOTE:** Field-supplied conduit may need to be installed depending on unit/curb configuration. Use #18 AWG solid conductor wire whenever connecting thermostat wires to terminals on sub-base. DO NOT use larger than #18 AWG wire. A transition to #18 AWG wire may be required before entering thermostat sub-base.

**NOTE:** Refer to unit wiring diagrams for thermostat hookups.

### CIRCULATING AIR AND FILTERS

#### DUCTWORK

The supply duct from the unit through a wall may be installed without clearance. However, minimum unit clearances must be maintained (see "Clearances" section). The supply duct should be provided with an access panel large enough to inspect the air chamber downstream of the heat exchanger. A cover should be tightly attached to prevent air leaks.

Ductwork dimensions are shown in the roof curb installation manual.

If desired, supply and return duct connections to the unit may be made with flexible connections to reduce possible unit operating sound transmission.

### CONDENSATE DRAIN CONNECTION

#### CONDENSATE DRAIN CONNECTION

A 3/4" female NPT drain connection is supplied on the end of the unit and bottom of the drain pan for condensate piping. An external trap must be installed for proper condensate drainage.

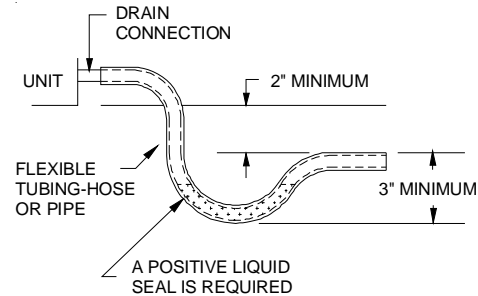

Install condensate drain trap as shown. Use 3/4" drain line and fittings or larger. Do not operate without trap.

#### HORIZONTAL DRAIN

Drainage of condensate directly onto the roof may be acceptable; refer to local code. It is recommended that a small drip pad of either stone, mortar, wood or metal be provided to prevent any possible damage to the roof.

#### CLEANING

Due to the fact that drain pans in any air conditioning unit will have some moisture in them, algae and fungus will grow due to airborne bacteria and spores. Periodic cleaning is necessary to prevent this build-up from plugging the drain.



## STARTUP, ADJUSTMENTS, AND CHECKS

### WARNING

#### HIGH VOLTAGE!

TO AVOID PERSONAL INJURY OR DEATH DUE TO ELECTRICAL SHOCK, BOND THE FRAME OF THIS UNIT TO THE BUILDING ELECTRICAL GROUND BY USE OF THE GROUNDING TERMINAL PROVIDED OR OTHER ACCEPTABLE MEANS. DISCONNECT ALL POWER BEFORE SERVICING OR INSTALLING THIS UNIT.



#### PRE-STARTUP INSTRUCTIONS

### CAUTION

TO PREVENT PROPERTY DAMAGE OR PERSONAL INJURY, DO NOT START THE UNIT UNTIL ALL NECESSARY PRE-CHECKS AND TESTS HAVE BEEN PERFORMED.

Prior to the beginning of Startup, Adjustments, and Checks procedures, the following steps should be completed in the building.

### WARNING

#### MOVING MACHINERY HAZARD!

TO PREVENT POSSIBLE PERSONAL INJURY OR DEATH, DISCONNECT POWER TO THE UNIT AND PADLOCK IN THE "OFF" POSITION BEFORE SERVICING FANS.

#### HEATING STARTUP

On new installations, or if a major component has been replaced, the operation of the unit must be checked.

Check unit operation as outlined in the following instructions. If any sparking, odors, or unusual sounds are encountered, shut off electrical power and recheck for wiring errors, or obstructions in or near the blower motors. **Duct covers must be removed before operating unit.**

The Startup, Adjustments, and Checks procedure provides a step-by-step sequence which, if followed, will assure the proper startup of the equipment in the minimum amount of time. Air balancing of duct system is not considered part of this procedure. However, it is an important phase of any air conditioning system startup and should be performed upon completion of the Startup, Adjustments, and Checks procedure. The Startup, Adjustments, and Checks procedure at outside ambients below 55°F should be limited to a readiness check of the refrigeration system with the required final check and calibration left to be completed when the outside ambient rises above 55°F.

#### TEMPORARY HEATING OR COOLING

If the unit is to be used for temporary heating or cooling, a "Startup, Adjustments, and Checks" must first be performed in accordance with this manual. Damage or repairs due to failure to comply with these requirements are not covered under the warranty. **After** the machines are used for temporary heating or cooling, inspect the coils, fans, and motors for unacceptable levels of construction dust and dirt and install new filters.

#### CONTRACTOR RESPONSIBILITY

The installing contractor must be certain that:

- All supply and return air ductwork is in place, properly sealed, and corresponds with installation instructions.
- All thermostats are mounted and wired in accordance with installation instructions.
- All electric power, all gas, hot water or steam line connections, and the condensate drain installation have been made to each unit on the job. These main supply lines must be functional and capable of operating all units simultaneously.
- All filters are in place.

#### ROOF CURB INSTALLATION CHECK

Inspect the roof curb for correct installation. The unit and curb assembly should be level. Inspect the flashing of the roof mounting curb to the roof, especially at the corners, for good workmanship. Also check for leaks around gaskets. Note any deficiencies in a separate report and forward to the contractor.

#### OBSTRUCTIONS, FAN CLEARANCE AND WIRING

Remove any extraneous construction and shipping materials that may be found during this procedure. Rotate all fans manually to check for proper clearances and that they rotate freely. Check for bolts and screws that may have jarred loose during shipment to the job site. Retighten if necessary. Re-tighten all electrical connections.

#### FIELD DUCT CONNECTIONS

Verify that all duct connections are tight and that there is no air bypass between supply and return.

#### FILTER SECTION CHECK

Remove filter section access panels and check that filters are properly installed. Note airflow arrows on filter frames.

#### PRE-STARTUP PRECAUTIONS

It is important to your safety that the unit has been properly grounded during installation. Check ground lug connection in main control box for tightness prior to closing circuit breaker or disconnect switch. Verify that supply voltage on line side of disconnect agrees with voltage on unit identification plate and is within the utilization voltage range as indicated in Appendix B Electrical Data.

**System Voltage** - That nominal voltage value assigned to a circuit or system for the purpose of designating its voltage class.

**Nameplate Voltage** - That voltage assigned to a piece of equipment for the purpose of designating its voltage class and for the purpose of defining the minimum and maximum voltage at which the equipment will operate.

**Utilization Voltage** - The voltage of the line terminals of the equipment at which the equipment must give fully satisfactory performance. Once it is established that supply voltage will be maintained within the utilization range under all system conditions, check and calculate if an unbalanced condition exists between phases. Calculate percent voltage unbalance as follows:

### Three Phase Models Only

$$3) \text{ PERCENT VOLTAGE UNBALANCE} = 100 \times \frac{2) \text{ MAXIMUM VOLTAGE DEVIATIONS FROM AVERAGE VOLTAGE}}{1) \text{ AVERAGE VOLTAGE}}$$

HOW TO USE THE FORMULA:

EXAMPLE: With voltage of 220, 216, and 213

1) Average Voltage =  $220+216+213=649 / 3 = 216$

2) Maximum Voltage Deviations from Average Voltage =  $220 - 216 = 4$

3) Percent Voltage Unbalance =  $100 \times \frac{4}{216} = \frac{400}{216} = 1.8\%$

Percent voltage unbalance **MUST NOT** exceed 2%.

### AIR FLOW ADJUSTMENTS

When the final adjustments are complete, the current draw of the motor should be checked and compared to the full load current rating of the motor. The amperage must not exceed the service factor stamped on the motor nameplate. The total airflow must not be less than that required for operation of the electric heaters or the furnace.

If an economizer is installed, check the unit operating balance with the economizer at full outside air and at minimum outside air.

**NOTE:** Never run CFM below 300 CFM per ton, evaporator freezing or poor unit performance is possible.

### EEM MOTOR

Adjust the CFM for the unit by changing the position of the low voltage leads on the motor terminal block. Green is for Fan Only. Yellow is for Cooling and Heat Pump Heating. Refer to Appendix A for blower performance at each speed tap. **NOTE:** If more than one lead is energized simultaneously, the motor will run at the higher speed.

### REFRIGERATION SYSTEM CHECKS

This unit is equipped with a piston type metering device.

Ensure the hold-down bolts on the compressor are secure and have not vibrated loose during shipment. Check that the vibration grommets have been installed and visually check all piping for damage and leaks and repair if necessary. The entire system has been factory charged and tested, making it unnecessary to field charge. Factory refrigerant charge is shown on the unit's nameplate.

To confirm charge levels or, if a leak occurs and charge needs to be added to the system, it is recommended to evacuate the system and recharge refrigerant to the unit's nameplate specifications. This unit has been rated in the cooling mode at the AHRI rated conditions of: indoor (80°F db/67°F wb) and outdoor (95°F db). While operating at this condition, the superheat should range from 9°F to 11°F for each refrigeration circuit measured at the suction service port located near the compressor.

### START-UP PROCEDURE AND CHECKLIST

Begin with power turned off at all disconnects.

#### AIR CONDITIONING START-UP PROCEDURE

1. Turn thermostat system switch to "Cool," and fan switch to "Auto" and turn temperature setting as high as it will go.
2. Inspect all registers and set them to the normal open position.
3. Turn on the electrical supply at the disconnect.
4. Turn the fan switch to the "ON" position. The blower should operate after a 7 second delay.
5. Turn the fan switch to "Auto" position. The blower should stop after a 65 second delay.
6. Slowly lower the cooling temperature until the unit starts. The compressor, blower and fan should now be operating. Allow the unit to run 10 minutes, make sure cool air is being supplied by the unit.
7. Turn the temperature setting to the highest position, stopping the unit. The indoor blower will continue to run for 65 seconds.
8. Turn the thermostat system switch to "OFF" and disconnect all power when servicing the unit.

#### **WARNING**

**HIGH VOLTAGE!**  
DISCONNECT ALL POWER BEFORE SERVICING OR INSTALLING THIS UNIT. MULTIPLE POWER SOURCES MAY BE PRESENT. FAILURE TO DO SO MAY CAUSE PROPERTY DAMAGE, PERSONAL INJURY OR DEATH.



#### HEAT PUMP START-UP PROCEDURE

9. Check the cooling mode for the heat pump in the same manner as above. The reversing valve is energized when the thermostat is placed in the cooling position. A clicking sound should be noticeable from the reversing valve. By lowering the temperature setting to call for cooling, the contractor is energized. The compressor, blower and fan should then be running. After the cooling mode is checked out, turn the thermostat system switch to "OFF".
10. Turn the thermostat system switch to "HEAT" and fan switch to "AUTO".
11. Slowly raise the heating temperature setting. When the heating first stage makes contact, stop raising the temperature setting. The compressor, blower and fan should now be running with the reversing valve in the de-energized (heating) position. After giving the unit time to settle out, make sure the unit is supplying heated air.

12. If the outdoor ambient is above 80°F, the unit may trip on its high pressure cut out when on heating. The compressor should stop. The heating cycle must be thoroughly checked, so postpone the test to another day when conditions are more suitable but-DO NOT FAIL TO TEST.

If the outdoor ambient is low and the unit operates properly on the heating cycle, you may check the pressure cutout operation by blocking off the indoor return air until the unit trips.

13. If unit operates properly in the heating cycle, raise the temperature setting until the heating second stage makes contact. Supplemental resistance heat, if installed should now come on. Make sure it operates properly.

**NOTE:** If outdoor thermostats are installed the outdoor ambient must be below the set point of these thermostats for the heaters to operate. It may be necessary to jumper these thermostats to check heater operation if outdoor ambient is mild.

14. For thermostats with emergency heat switch, return to step 11. The emergency heat switch is located at the bottom of the thermostat. Move the switch to emergency heat. The heat pump will stop, the blower will continue to run, all heaters will come on and the thermostat emergency heat light will come on.

15. If checking the unit in the wintertime, when the outdoor coil is cold enough to actuate the defrost control, observe at least one defrost cycle to make sure the unit defrosts completely.

#### FINAL SYSTEM CHECKS

16. Check to see if all supply and return air grilles are adjusted and the air distribution system is balanced for the best compromise between heating and cooling.

17. Check for air leaks in the ductwork. See Sections on **Air Flow Adjustments**.

18. Make sure the unit is free of "rattles", and the tubing in the unit is free from excessive vibration. Also make sure tubes or lines are not rubbing against each other or sheet metal surfaces or edges. If so, correct the trouble.

19. Set the thermostat at the appropriate setting for cooling and heating or automatic changeover for normal use.

20. Be sure the Owner is instructed on the unit operation, filter, servicing, correct thermostat operation, etc.

#### REFRIGERATION PERFORMANCE CHECK

Check that compressor RLA corresponds to values shown in Appendix B. RLA draw can be much lower than values listed at low load conditions and low ambient condensing temperatures. Values in Appendix B can slightly exceed at high load conditions and high ambient condensing temperatures.

## HEAT PUMP OPERATION

### COOLING CYCLE

When the heat pump is in the cooling cycle, it operates exactly as a Summer Air Conditioner unit. In this mode, all the charts and data for service that apply to summer air conditioning apply to the heat pump. Most apply on the heating cycle except that "condenser" becomes "evaporator", "evaporator" becomes "condenser", "cooling" becomes "heating".

### HEATING CYCLE

The heat pump operates in the heating cycle by redirecting refrigerant flow through the refrigerant circuit external to the compressor. This is accomplished with through the reversing valve. Hot discharge vapor from the compressor is directed to the indoor coil (evaporator on the cooling cycle) where the heat is removed, and the vapor condenses to liquid. It then goes through the expansion device to the outdoor coil (condenser on the cooling cycle) where the liquid is evaporated, and the vapor goes to the compressor.

When the solenoid valve coil is operated either from heating to cooling or vice versa, the piston in the reversing valve to the low pressure (high pressure) reverse positions in the reversing valve.

The following figures show a schematic of a heat pump on the cooling cycle and the heating cycle. In addition to a reversing valve, a heat pump is equipped with an expansion device and check valve for the indoor coil, and similar equipment for the outdoor coil. It is also provided with a defrost control system.

The expansion devices are flowrator distributors and perform the same function on the heating cycle as on the cooling cycle. The flowrator distributors also act as check valves to allow for the reverse of refrigerant flow.

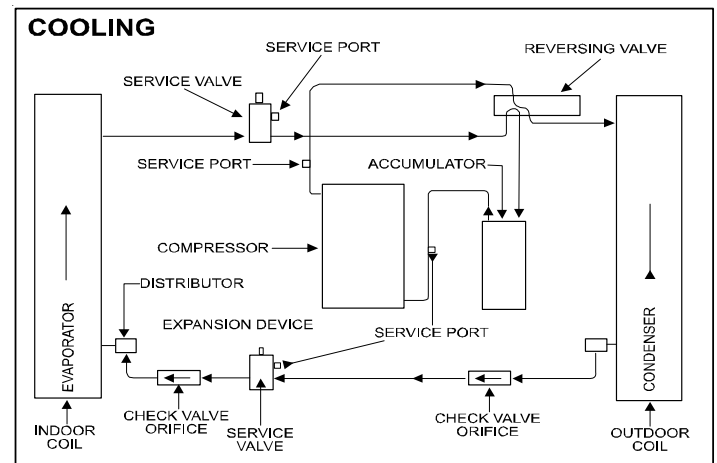

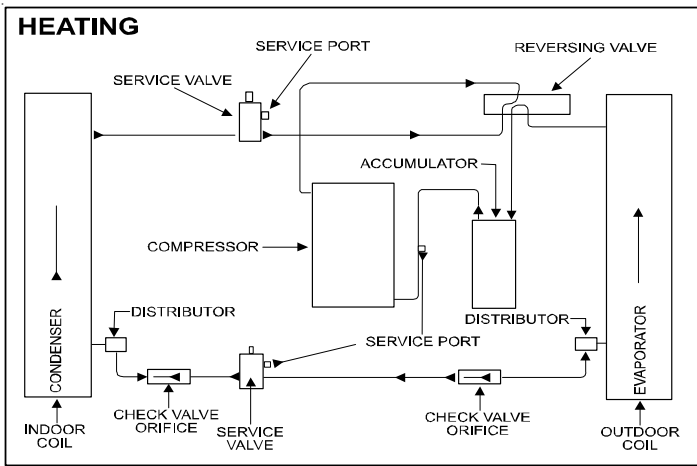

When the heat pump is on the heating cycle, the outdoor coil is functioning as an evaporator. The temperature of the refrigerant in the outdoor coil must be below the temperature of the outdoor air in order to extract heat from the air. Thus, the greater the difference in the outdoor temperature and the outdoor coil temperature, the greater the heating capacity of the heat pump. This phenomenon is a characteristic of a heat pump. It is a good practice to provide supplementary heat for all heat pump installations in areas where the temperature drops below 45° F. It is also a good practice to provide sufficient supplementary heat to handle the entire heating requirement should there be a component failure of the heat pump, such as a compressor, or refrigerant leak, etc.

Since the temperature of the refrigerant in the outdoor coil on the heating cycle is generally below freezing point, frost forms on the surfaces of the outdoor coil under certain weather conditions of temperature and relative humidity. Therefore, it is necessary to reverse the flow of the refrigerant to provide hot gas in the outdoor coil to melt the frost accumulation. This is accomplished by reversing the heat pump to the cooling cycle. At the same time, the outdoor fan stops to hasten the temperature rise of the outdoor coil and lessen the time required for defrosting. The indoor blower continues to run and the supplementary heaters are energized.

### DEFROST CONTROL

During operation the power to the circuit board is controlled by a temperature sensor, which is clamped to a feeder tube entering the outdoor coil. Defrost timing periods of 30, 60 and 90 minutes may be selected by connecting the circuit board jumper to 30, 60 and 90 respectively. Accumulation of time for the timing period selected starts when the sensor closes (approximately 31° F), and when the wall thermostat calls for heat. At the end of the timing period, the unit's defrost cycle will be initiated provided the sensor remains closed. When the sensor opens (approximately 75° F), the defrost cycle is terminated and the timing period is reset. If the defrost cycle is not terminated due to the sensor temperature, a ten minute override interrupts the unit's defrost period.

## MAINTENANCE

### WARNING

**HIGH VOLTAGE!**  
DISCONNECT ALL POWER BEFORE SERVICING OR INSTALLING THIS UNIT. MULTIPLE POWER SOURCES MAY BE PRESENT. FAILURE TO DO SO MAY CAUSE PROPERTY DAMAGE, PERSONAL INJURY OR DEATH.



### WARNING

**TO PREVENT PERSONAL INJURY OR DEATH DUE TO IMPROPER INSTALLATION, ADJUSTMENT, ALTERATION, SERVICE OR MAINTENANCE, REFER TO THIS MANUAL. FOR ADDITIONAL ASSISTANCE OR INFORMATION, CONSULT A QUALIFIED INSTALLER, SERVICE AGENCY OR THE GAS SUPPLIER.**

### CAUTION

**SHEET METAL PARTS, SCREWS, CLIPS AND SIMILAR ITEMS INHERENTLY HAVE SHARP EDGES, AND IT IS NECESSARY THAT THE INSTALLER AND SERVICE PERSONNEL EXERCISE CAUTION.**

The Self Contained Packaged Air Conditioner and Heat Pump should operate for many years without excessive service calls if the unit is installed properly. However it is recommended that the homeowner inspect the unit before a seasonal start up. The coils should be free of debris so adequate airflow is achieved. The return and supply registers should be free of any obstructions. The filters should be cleaned or replaced. These few steps will help to keep the product up time to a maximum. The Service section that follows should help in identifying problems if the unit does not operate properly.

### FILTERS

### CAUTION

**TO PREVENT PROPERTY DAMAGE DUE TO FIRE AND LOSS OF EQUIPMENT EFFICIENCY OR EQUIPMENT DAMAGE DUE TO DUST AND LINT BUILD UP ON INTERNAL PARTS, NEVER OPERATE UNIT WITHOUT AN AIR FILTER INSTALLED IN THE RETURN AIR SYSTEM.**

Every application may require a different frequency of replacement of dirty filters. Filters must be replaced at least every three (3) months during operating seasons.

Dirty filters are the most common cause of inadequate heating or cooling performance. Filter inspection should be made at least every two months; more often if necessary because of local conditions and usage.

Dirty throwaway filters should be discarded and replaced with a new, clean filter.

Disposable return air filters are supplied with this unit. See the unit Specification Sheet or Technical Manual for the correct size and part number. To remove the filters, remove the filter access panel on return side of the unit.

## CABINET FINISH MAINTENANCE

Use a fine grade automotive wax on the cabinet finish to maintain the finish's original high luster. This is especially important in installations with extended periods of direct sunlight.

## CLEAN OUTSIDE COIL (QUALIFIED SERVICER ONLY)

The coil with the outside air flowing over it should be inspected annually and cleaned as frequently as necessary to keep the finned areas free of lint, hair and debris.

## LUBRICATION

The fan shaft bearings, the 1 to 2 HP supply fan motors, the condenser fan motors and compressors are permanently lubricated.

## FUNCTIONAL PARTS

Refer to the unit Parts Catalog for a list of functional parts. Parts are available from your distributor.

## TROUBLESHOOTING

THE FOLLOWING INFORMATION IS FOR USE BY QUALIFIED SERVICE AGENCY ONLY: OTHERS SHOULD NOT ATTEMPT TO SERVICE THIS EQUIPMENT.

### Common Causes of Unsatisfactory Operation of Heat Pump on the Heating Cycle.

#### *INADEQUATE AIR VOLUME THROUGH INDOOR COIL*

When a heat pump is in the heating cycle, the indoor coil is functioning as a condenser. The return air filter must always be clean, and sufficient air volume must pass through the indoor coil to prevent excessive discharge pressure, and high pressure cut out.

#### *OUTSIDE AIR INTO RETURN DUCT*

Do not introduce cold outside air into the return duct of a heat pump installation. For units with 2-speed motors, do not allow air entering the indoor coil to drop below 65° F. Air below this temperature will cause low discharge pressure, thus low suction pressure, and excessive defrost cycling resulting in low heating output. It may also cause false defrosting.

#### *UNDERCHARGE*

An undercharged heat pump on the heating cycle will cause low discharge pressure resulting in low suction pressure and frost accumulation on the outdoor coil.

#### *POOR "TERMINATING" SENSOR CONTACT*

The unit's defrost terminating sensor must make good thermal contact with the outdoor coil tubing. Poor contact may not terminate the unit's defrost cycle quickly enough to prevent the unit from cutting out on high discharge pressure.

#### *MALFUNCTIONING REVERSING VALVE - THIS MAY BE DUE TO:*

1. **Solenoid not energized** - In order to determine if the solenoid is energized, touch the nut that holds the solenoid cover in place with a screwdriver. If the nut magnetically holds the screwdriver, the solenoid is energized and the unit is in the cooling cycle.
2. **No voltage at unit's solenoid** - Check unit voltage. If no voltage, check wiring circuit.

#### 3. **Valve will not shift:**

- a. **Undercharged** - check for leaks;
- b. **Valve Body Damaged** - Replace valve;
- c. **Unit Properly Charged** - If it is on the heating cycle, raise the discharge pressure by restricting airflow through the indoor coil. If the valve does not shift, tap it **lightly** on both ends with a screwdriver handle. **DO NOT TAP THE VALVE BODY.** If the unit is on the cooling cycle, raise the discharge pressure by restricting airflow through the outdoor coil. If the valve does not shift after the above attempts, cut the unit off and wait until the discharge and suction pressure equalize, and repeat above steps. If the valve does not shift, replace it.

# APPENDIX A BLOWER PERFORMANCE TABLES DIRECT DRIVE STANDARD DOWN SHOT AND HORIZONTAL

STANDARD DTC/DTH036

## DOWNSHOT

SPEED TAP	EXTERNAL STATIC PRESSURE (ESP)	STANDARD CFM	AMPS	WATTS	RPM
T1	0.1	966	0.50	108	657
	0.2	850	0.52	115	710
	0.3	773	0.55	122	763
	0.4	678	0.59	130	819
	0.5	593	0.62	141	875
	0.6				
	0.7				
	0.8				
	0.9				
T2	0.1	1057	0.60	134	693
	0.2	956	0.62	140	740
	0.3	868	0.66	144	787
	0.4	788	0.69	156	839
	0.5	700	0.73	166	898
	0.6	618	0.76	174	946
	0.7				
	0.8				
	0.9				
T3	0.1	1234	0.86	199	784
	0.2	1146	0.89	206	822
	0.3	1068	0.92	213	863
	0.4	977	0.96	221	910
	0.5	911	1.00	232	949
	0.6	842	1.04	245	998
	0.7	776	1.08	253	1031
	0.8	703	1.11	263	1082
	0.9	682	1.13	266	1107
T4	0.1	1363	1.03	242	822
	0.2	1253	1.09	251	874
	0.3	1176	1.12	260	910
	0.4	1110	1.15	270	940
	0.5	1034	1.19	279	981
	0.6	966	1.23	290	1028
	0.7	899	1.27	301	1074
	0.8	836	1.33	312	1117
	0.9	778	1.35	319	1146
T5	0.1	1413	1.14	268	849
	0.2	1299	1.18	275	899
	0.3	1233	1.23	259	933
	0.4	1166	1.26	296	963
	0.5	1096	1.30	307	1000
	0.6	1026	1.34	318	1040
	0.7	960	1.39	330	1052
	0.8	889	1.44	340	1132
	0.9	835	1.47	347	1169

## HORIZONTAL

SPEED TAP	EXTERNAL STATIC PRESSURE (ESP)	STANDARD CFM	AMPS	WATTS	RPM
T1	0.1	1018	0.47	101	615
	0.2	969	0.49	109	653
	0.3	881	0.53	117	712
	0.4	818	0.55	125	768
	0.5	732	0.59	135	833
	0.6	658	0.63	142	890
	0.7	616	0.65	148	938
	0.8				
	0.9				
T2	0.1	1128	0.56	126	645
	0.2	1070	0.59	132	692
	0.3	994	0.62	138	727
	0.4	915	0.66	149	791
	0.5	839	0.69	156	838
	0.6	776	0.73	169	909
	0.7	698	0.77	179	963
	0.8	649	0.80	183	1003
	0.9				
T3	0.1	1293	0.81	186	733
	0.2	1252	0.84	193	765
	0.3	1198	0.87	204	803
	0.4	1130	0.91	212	844
	0.5	1075	0.94	218	886
	0.6	1015	0.98	230	930
	0.7	941	1.02	242	984
	0.8	870	1.08	253	1045
	0.9	817	1.11	262	1080
T4	0.1	1404	0.99	232	789
	0.2	1367	1.02	240	817
	0.3	1334	1.05	244	845
	0.4	1265	1.09	257	882
	0.5	1207	1.13	265	922
	0.6	1153	1.17	272	958
	0.7	1090	1.21	283	1005
	0.8	1029	1.25	299	1052
	0.9	947	1.31	312	1111
T5	0.1	1457	1.08	254	805
	0.2	1413	1.12	266	839
	0.3	1359	1.16	273	870
	0.4	1307	1.20	285	911
	0.5	1253	1.23	291	940
	0.6	1197	1.28	304	978
	0.7	1138	1.31	310	1017
	0.8	1082	1.36	322	1059
	0.9	1029	1.41	335	1105

**Notes:**

Table represent dry coil without filter, to compensate for filter add 0.08" to measured E.S.P.. SCFM correction for wet coil = 4%. 5 Ton models are shipped from the factory with speed tap set on T4.

# APPENDIX A BLOWER PERFORMANCE TABLES DIRECT DRIVE STANDARD DOWN SHOT AND HORIZONTAL

STANDARD DTC/DTH048

## DOWNSHOT

## HORIZONTAL

SPEED TAP	EXTERNAL STATIC PRESSURE (ESP) in w.c.	STANDARD CFM	AMPS	WATTS	RPM
T1	0.1	1286	0.82	187	667
	0.2	1205	0.86	198	704
	0.3	1139	0.80	205	731
	0.4	1052	0.92	212	764
	0.5	982	0.95	215	790
	0.6	911	0.97	224	814
	0.7	840	1.00	230	837
	0.8	779	1.02	235	855
	0.9	717	1.04	242	879
T2	0.1	1470	1.09	251	726
	0.2	1399	1.12	260	758
	0.3	1315	1.16	271	790
	0.4	1253	1.19	281	814
	0.5	1180	1.22	287	842
	0.6	1110	1.26	292	867
	0.7	1042	1.29	300	891
	0.8	973	1.32	308	914
	0.9	916	1.34	314	933
T3	0.1	1747	1.75	413	855
	0.2	1668	1.80	414	884
	0.3	1609	1.84	436	908
	0.4	1557	1.88	442	931
	0.5	1489	1.92	453	957
	0.6	1419	1.97	476	984
	0.7	1377	2.00	472	1002
	0.8	1311	2.03	479	1022
	0.9	1256	2.07	488	1044
T4	0.1	1879	2.11	504	908
	0.2	1799	2.16	512	935
	0.3	1730	2.20	525	955
	0.4	1677	2.26	539	981
	0.5	1630	2.31	547	1006
	0.6	1558	2.35	557	1032
	0.7	1508	2.38	553	1049
	0.8	1443	2.43	588	1072
	0.9	1389	2.48	585	1091
T5	0.1	1903	2.28	542	931
	0.2	1838	2.31	561	952
	0.3	1785	2.38	571	977
	0.4	1723	2.41	574	1002
	0.5	1666	2.46	585	1020
	0.6	1612	2.51	596	1048
	0.7	1547	2.56	611	1067
	0.8	1505	2.59	607	1083
	0.9	1445	2.63	613	1109

SPEED TAP	EXTERNAL STATIC PRESSURE (ESP) in w.c.	STANDARD CFM	AMPS	WATTS	RPM
T1	0.1	1346	0.77	176	622
	0.2	1286	0.80	186	657
	0.3	1211	0.84	198	698
	0.4	1144	0.88	204	730
	0.5	1068	0.92	214	768
	0.6	996	0.95	222	798
	0.7	923	0.98	229	829
	0.8	839	1.01	235	857
	0.9	777	1.04	242	881
T2	0.1	1534	1.01	234	681
	0.2	1482	1.05	246	710
	0.3	1412	1.09	256	745
	0.4	1352	1.13	263	774
	0.5	1286	1.17	272	806
	0.6	1216	1.19	281	839
	0.7	1147	1.24	289	868
	0.8	1077	1.27	299	892
	0.9	1002	1.31	309	922
T3	0.1	1515	1.61	382	787
	0.2	1762	1.65	392	809
	0.3	1697	1.69	399	835
	0.4	1651	1.74	416	863
	0.5	1598	1.79	423	892
	0.6	1533	1.85	438	922
	0.7	1464	1.89	447	951
	0.8	1417	1.94	458	975
	0.9	1361	1.97	475	999
T4	0.1	1941	1.96	464	834
	0.2	1888	1.99	471	853
	0.3	1847	2.04	491	876
	0.4	1790	2.09	502	906
	0.5	1742	2.14	509	928
	0.6	1682	2.19	537	957
	0.7	1620	2.26	5337	987
	0.8	1576	2.28	547	1010
	0.9	1521	2.33	556	1034
T5	0.1	1994	2.09	497	845
	0.2	1946	2.16	511	876
	0.3	1893	2.15	518	896
	0.4	1865	2.28	536	923
	0.5	1795	2.26	548	351
	0.6	1741	2.39	555	376
	0.7	1681	2.38	572	999
	0.8	1630	2.47	597	1023
	0.9	1576	2.47	595	1046

**Notes:**

Table represent dry coil without filter, to compensate for filter add 0.08" to measured E.S.P.. SCFM correction for wet coil = 4%. 5 Ton models are shipped from the factory with speed tap set on T4.

# APPENDIX A BLOWER PERFORMANCE TABLES

## DIRECT DRIVE

### STANDARD DTC/DTH060 DOWN SHOT

SPEED TAP	EXTERNAL STATIC PRESSURE (ESP) in w.c.	STANDARD CFM	AMPS	WATTS	RPM
T1	0.10	1334	1.65	180	627
	0.20	1286	1.75	192	665
	0.30	1212	1.83	202	715
	0.40	1144	1.94	216	759
	0.50	1077	1.99	222	792
	0.60	1039	2.10	238	830
	0.70	953	2.17	248	874
	0.80	904	2.27	258	913
T2	0.90	825	2.30	266	940
	0.10	1512	2.12	240	682
	0.20	1469	2.24	254	720
	0.30	1397	2.31	264	759
	0.40	1333	2.44	282	803
	0.50	1285	2.54	296	836
	0.60	1221	2.59	304	874
	0.70	1173	2.72	322	913
T3	0.80	1118	2.77	328	946
	0.90	1049	2.90	344	984
	0.10	2053	4.27	540	869
	0.20	2014	4.39	558	896
	0.30	1999	4.60	576	929
	0.40	1947	4.68	588	957
	0.50	1897	4.79	608	989
	0.60	1857	4.87	620	1012
T4	0.70	1763	4.99	640	1050
	0.80	1741	5.06	650	1072
	0.90	1669	5.19	668	1105
	0.10	2137	4.95	634	913
	0.20	2093	5.07	652	940
	0.30	2095	5.19	670	962
	0.40	2026	5.28	682	990
	0.50	1980	5.40	698	1018
T5	0.60	1961	5.49	720	1039
	0.70	1914	5.58	732	1072
	0.80	1845	5.70	742	1100
	0.90	1766	5.69	740	1127
	0.10	2299	5.70	742	942
	0.20	2233	5.80	748	969
	0.30	2217	5.90	768	990
	0.40	2157	6.07	786	1018
T5	0.50	2131	6.12	804	1045
	0.60	2060	6.21	816	1073
	0.70	2015	6.30	820	1095
	0.80	1940	6.27	816	1111
	0.90	1862	6.13	790	1128

**NOTES:**

Tables represent dry coil without filter, to compensate for filter add 0.08" to measured E.S.P. SCFM correction for wet coil = 4%. 5 Ton models are shipped from the factory with speed tap set on T4.



# APPENDIX A BLOWER PERFORMANCE TABLES

## DIRECT DRIVE

### STANDARD DTC/DTH060 HORIZONTAL

SPEED TAP	EXTERNAL STATIC PRESSURE (ESP) in w.c.	STANDARD CFM	AMPS	WATTS	RPM
T1	0.10	1355	1.57	174	599
	0.20	1281	1.66	182	651
	0.30	1235	1.76	196	693
	0.40	1168	1.81	202	726
	0.50	1118	1.94	218	775
	0.60	1049	2.03	232	819
	0.70	982	2.10	240	858
	0.80	922	2.14	246	885
T2	0.10	1544	2.04	234	660
	0.20	1490	2.17	250	704
	0.30	1427	2.25	260	742
	0.40	1370	2.35	276	781
	0.50	1319	2.42	282	809
	0.60	1274	2.52	296	849
	0.70	1210	2.62	316	891
	0.80	1137	2.73	326	935
T3	0.10	2099	4.13	516	825
	0.20	2068	4.25	536	852
	0.30	2029	4.37	552	885
	0.40	1971	4.48	568	913
	0.50	1911	4.61	586	950
	0.60	1876	4.73	604	973
	0.70	1821	4.86	622	1012
	0.80	1792	4.91	630	1028
T4	0.10	2233	4.76	608	863
	0.20	2168	4.91	628	896
	0.30	2125	5.02	640	924
	0.40	2070	5.14	660	951
	0.50	2050	5.27	678	979
	0.60	1980	5.41	696	1012
	0.70	1954	5.47	704	1034
	0.80	1893	5.60	724	1067
T5	0.10	2322	5.44	710	904
	0.20	2294	5.55	726	934
	0.30	2254	5.68	742	958
	0.40	2201	5.80	766	990
	0.50	2147	5.93	782	1017
	0.60	2117	6.01	788	1039
	0.70	2081	6.12	808	1060
	0.80	2017	6.22	822	1094
	0.90	1932	6.10	804	1111

**NOTES:**

Tables represent dry coil without filter, to compensate for filter add 0.08" to measured E.S.P. SCFM correction for wet coil = 4 %.

5 Ton models are shipped from the factory with speed tap set on T4.

# APPENDIX B ELECTRICAL DATA

Model Number	Electrical Rating	Compressor Circuit 1		Compressor Circuit 2		Outdoor Fan Motor			Indoor Fan Motor			Optional Electric Heat			Optional Powered Convenience Outlet	Power Supply	
		RLA	LRA	RLA	LRA	QTY	HP	FLA	Type	HP	FLA	Part #	KW*	FLA	FLA	MCA	MOP
DTC036XXX1D	208/230-1-60	14.1	77.0			1	0.25	1.40	Standard - Direct Drive	0.50	3.90	-	-	-	-	22.9 / 22.9	35 / 35
												EHK1-10	7.5 / 10.0	36.1 / 41.7	-	50.0 / 57.0	50 / 60
												EHK1-15	11.3 / 15.0	54.2 / 62.5	-	72.6 / 83.0	80 / 90
												-	-	-	7.2 / 6.5	30.1 / 29.4	40 / 40
												EHK1-10	7.5 / 10.0	36.1 / 41.7	7.2 / 6.5	59.0 / 65.1	60 / 70
EHK1-15	11.3 / 15.0	54.2 / 62.5	7.2 / 6.5	81.6 / 91.1	90 / 100												
DTC036XXX3D	208/230-3-60	9.0	71.0			1	0.25	1.40	Standard - Direct Drive	0.50	3.90	-	-	-	-	16.5 / 16.5	25 / 25
												EHK3-10	7.5 / 10.0	20.8 / 24.0	-	30.9 / 34.9	35 / 35
												EHK3-15	11.3 / 15.0	31.3 / 36.1	-	44.0 / 50.0	45 / 50
												-	-	-	7.2 / 6.5	23.7 / 23.0	30 / 30
												EHK3-10	7.5 / 10.0	20.8 / 24.0	7.2 / 6.5	39.9 / 43.0	40 / 45
EHK3-15	11.3 / 15.0	31.3 / 36.1	7.2 / 6.5	53.0 / 58.1	60 / 60												

Model Number	Electrical Rating	Compressor Circuit 1		Compressor Circuit 2		Outdoor Fan Motor			Indoor Fan Motor			Optional Electric Heat			Optional Powered Convenience Outlet	Power Supply	
		RLA	LRA	RLA	LRA	QTY	HP	FLA	Type	HP	FLA	Part #	KW*	FLA	FLA	MCA	MOP
DTH036XXX1D	208/230-1-60	14.1	77.0			1	0.25	1.40	Standard - Direct Drive	0.50	3.90	-	-	-	-	22.9 / 22.9	35 / 35
												EHK1-10	7.5 / 10.0	36.1 / 41.7	-	68.1 / 75.1	70 / 80
												EHK1-15	11.3 / 15.0	54.2 / 62.5	-	90.7 / 101	100 / 110
												-	-	-	7.2 / 6.5	30.1 / 29.4	40 / 40
												EHK1-10	7.5 / 10.0	36.1 / 41.7	7.2 / 6.5	75.3 / 81.6	80 / 90
EHK1-15	11.3 / 15.0	54.2 / 62.5	7.2 / 6.5	97.9 / 108	100 / 110												
DTH036XXX3D	208/230-3-60	9.0	71.0			1	0.25	1.40	Standard - Direct Drive	0.50	3.90	-	-	-	-	16.5 / 16.5	25 / 25
												EHK3-10	7.5 / 10.0	20.8 / 24.0	-	42.5 / 46.5	45 / 50
												EHK3-15	11.3 / 15.0	31.3 / 36.1	-	55.6 / 61.6	60 / 70
												-	-	-	7.2 / 6.5	23.7 / 23.0	30 / 30
												EHK3-10	7.5 / 10.0	20.8 / 24.0	7.2 / 6.5	49.7 / 53.0	50 / 60
EHK3-15	11.3 / 15.0	31.3 / 36.1	7.2 / 6.5	62.8 / 68.1	70 / 70												

Model Number	Electrical Rating	Compressor Circuit 1		Compressor Circuit 2		Outdoor Fan Motor			Indoor Fan Motor			Optional Electric Heat			Optional Powered Convenience Outlet	Power Supply	
		RLA	LRA	RLA	LRA	QTY	HP	FLA	Type	HP	FLA	Part #	KW*	FLA	FLA	MCA	MOP
DTC048XXX1D	208/230-1-60	19.9	109.0			1	0.25	1.40	Standard - Direct Drive	1.00	6.90	-	-	-	-	33.1 / 33.1	50 / 50
												EHK1-10	7.5 / 10.0	36.1 / 41.7	-	53.8 / 60.8	60 / 70
												EHK1-15	11.3 / 15.0	54.2 / 62.5	-	76.4 / 86.8	80 / 90
												EHK1-18	13.5 / 18.0	65.0 / 75.0	-	89.9 / 102	90 / 110
												-	-	-	7.2 / 6.5	40.3 / 39.6	60 / 50
												EHK1-10	7.5 / 10.0	36.1 / 41.7	7.2 / 6.5	62.8 / 68.9	70 / 70
												EHK1-15	11.3 / 15.0	54.2 / 62.5	7.2 / 6.5	85.4 / 94.9	90 / 100
EHK1-18	13.5 / 18.0	65.0 / 75.0	7.2 / 6.5	98.9 / 111	100 / 125												
DTC048XXX3D	208/230-3-60	13.1	83.1			1	0.25	1.40	Standard - Direct Drive	1.00	6.90	-	-	-	-	24.7 / 24.7	35 / 35
												EHK3-10	7.5 / 10.0	20.8 / 24.0	-	34.6 / 38.6	35 / 40
												EHK3-15	11.3 / 15.0	31.3 / 36.1	-	47.8 / 53.8	50 / 60
												EHK3-18	13.5 / 18.0	37.5 / 43.3	-	55.5 / 62.8	60 / 70
												-	-	-	7.2 / 6.5	31.9 / 31.2	45 / 40
												EHK3-10	7.5 / 10.0	20.8 / 24.0	7.2 / 6.5	43.6 / 46.8	45 / 50
												EHK3-15	11.3 / 15.0	31.3 / 36.1	7.2 / 6.5	56.8 / 61.9	60 / 70
EHK3-18	13.5 / 18.0	37.5 / 43.3	7.2 / 6.5	64.5 / 70.9	70 / 80												

Model Number	Electrical Rating	Compressor Circuit 1		Compressor Circuit 2		Outdoor Fan Motor			Indoor Fan Motor			Optional Electric Heat			Optional Powered Convenience Outlet	Power Supply	
		RLA	LRA	RLA	LRA	QTY	HP	FLA	Type	HP	FLA	Part #	KW*	FLA	FLA	MCA	MOP
DTH048XXX1D	208/230-1-60	19.9	109.0			1	0.25	1.40	Standard - Direct Drive	1.00	6.90	-	-	-	-	33.1 / 33.1	50 / 50
												EHK1-10	7.5 / 10.0	36.1 / 41.7	-	78.3 / 85.3	80 / 90
												EHK1-15	11.3 / 15.0	54.2 / 62.5	-	101 / 111	110 / 125
												EHK1-18	13.5 / 18.0	65.0 / 75.0	-	114 / 127	125 / 150
												-	-	-	7.2 / 6.5	40.3 / 39.6	60 / 50
												EHK1-10	7.5 / 10.0	36.1 / 41.7	7.2 / 6.5	85.5 / 91.8	90 / 100
												EHK1-15	11.3 / 15.0	54.2 / 62.5	7.2 / 6.5	108 / 118	110 / 125
EHK1-18	13.5 / 18.0	65.0 / 75.0	7.2 / 6.5	122 / 133	125 / 150												
DTH048XXX3D	208/230-3-60	13.1	83.1			1	0.25	1.40	Standard - Direct Drive	1.00	6.90	-	-	-	-	24.7 / 24.7	35 / 35
												EHK3-10	7.5 / 10.0	20.8 / 24.0	-	50.7 / 54.7	60 / 60
												EHK3-15	11.3 / 15.0	31.3 / 36.1	-	63.9 / 69.9	70 / 70
												EHK3-18	13.5 / 18.0	37.5 / 43.3	-	71.6 / 78.9	80 / 80
												-	-	-	7.2 / 6.5	31.9 / 31.2	45 / 40
												EHK3-10	7.5 / 10.0	20.8 / 24.0	7.2 / 6.5	57.9 / 61.2	60 / 70
												EHK3-15	11.3 / 15.0	31.3 / 36.1	7.2 / 6.5	71.1 / 76.4	80 / 80
EHK3-18	13.5 / 18.0	37.5 / 43.3	7.2 / 6.5	78.8 / 85.4	80 / 90												

## APPENDIX B ELECTRICAL DATA

Model Number	Electrical Rating	Compressor Circuit 1		Compressor Circuit 2		Outdoor Fan Motor			Indoor Fan Motor			Optional Electric Heat			Optional Powered Convenience Outlet	Power Supply	
		RLA	LRA	RLA	LRA	QTY	HP	FLA	Type	HP	FLA	Part #	KW*	FLA	FLA	MCA	MOP
DTC060XXX1D	208/230-1-60	25.0	134.0			1	0.33	2.00	Standard-Direct Drive	1.00	6.90	-	-	-	-	40.2 / 40.2	60 / 60
												EHK1-10	7.5 / 10.0	36.1 / 41.7	-	53.8 / 60.8	60 / 70
												EHK1-15	11.3 / 15.0	54.2 / 62.5	-	76.4 / 86.8	80 / 90
												EHK1-20	15.0 / 20.0	72.2 / 83.3	-	98.9 / 113	100 / 125
												-	-	-	7.2 / 6.5	47.4 / 46.7	70 / 70
												EHK1-10	7.5 / 10.0	36.1 / 41.7	7.2 / 6.5	62.8 / 68.9	70 / 70
												EHK1-15	11.3 / 15.0	54.2 / 62.5	7.2 / 6.5	85.4 / 94.9	90 / 100
EHK1-20	15.0 / 20.0	72.2 / 83.3	7.2 / 6.5	108 / 121	110 / 125												
DTC060XXX3D	208/230-3-60	15.9	110.0			1	0.33	2.00	Standard-Direct Drive	1.00	6.90	-	-	-	-	28.8 / 28.8	40 / 40
												EHK3-10	7.5 / 10.0	20.8 / 24.0	-	34.6 / 38.6	40 / 40
												EHK3-15	11.3 / 15.0	31.3 / 36.1	-	47.8 / 53.8	50 / 60
												EHK3-20	15.0 / 20.0	41.6 / 48.0	-	60.6 / 68.6	70 / 70
												-	-	-	7.2 / 6.5	36.0 / 35.3	50 / 50
												EHK3-10	7.5 / 10.0	20.8 / 24.0	7.2 / 6.5	43.6 / 46.8	50 / 50
												EHK3-15	11.3 / 15.0	31.3 / 36.1	7.2 / 6.5	56.8 / 61.9	60 / 70
EHK3-20	15.0 / 20.0	41.6 / 48.0	7.2 / 6.5	69.6 / 76.8	70 / 80												

Model Number	Electrical Rating	Compressor Circuit 1		Compressor Circuit 2		Outdoor Fan Motor			Indoor Fan Motor			Optional Electric Heat			Optional Powered Convenience Outlet	Power Supply	
		RLA	LRA	RLA	LRA	QTY	HP	FLA	Type	HP	FLA	Part #	KW*	FLA	FLA	MCA	MOP
DTH060XXX1D	208/230-1-60	25.0	134.0			1	0.25	2.00	Standard-Direct Drive	1.00	6.90	-	-	-	-	40.2 / 40.2	60 / 60
												EHK1-10	7.5 / 10.0	36.1 / 41.7	-	85.3 / 92.3	100 / 100
												EHK1-15	11.3 / 15.0	54.2 / 62.5	-	108 / 118	110 / 125
												EHK1-20	15.0 / 20.0	72.2 / 83.3	-	130 / 144	150 / 150
												-	-	-	7.2 / 6.5	47.4 / 46.7	70 / 70
												EHK1-10	7.5 / 10.0	36.1 / 41.7	7.2 / 6.5	92.5 / 98.8	100 / 110
												EHK1-15	11.3 / 15.0	54.2 / 62.5	7.2 / 6.5	115 / 125	125 / 125
EHK1-20	15.0 / 20.0	72.2 / 83.3	7.2 / 6.5	138 / 151	150 / 175												
DTH060XXX3D	208/230-3-60	15.9	110.0			1	0.33	2.30	Standard-Direct Drive	1.00	6.90	-	-	-	-	29.1 / 29.1	45 / 45
												EHK3-10	7.5 / 10.0	20.8 / 24.0	-	55.1 / 59.1	60 / 60
												EHK3-15	11.3 / 15.0	31.3 / 36.1	-	68.2 / 74.2	70 / 80
												EHK3-20	15.0 / 20.0	41.6 / 48.0	-	81.1 / 89.1	90 / 90
												-	-	-	7.2 / 6.5	36.3 / 35.6	50 / 50
												EHK3-10	7.5 / 10.0	20.8 / 24.0	7.2 / 6.5	62.3 / 65.6	70 / 70
												EHK3-15	11.3 / 15.0	31.3 / 36.1	7.2 / 6.5	75.4 / 80.7	80 / 90
EHK3-20	15.0 / 20.0	41.6 / 48.0	7.2 / 6.5	88.3 / 95.6	90 / 100												

\*Electric Heater kW rating: Rated at 240v for 208-230v units; 480v for 460v units

### MINIMUM AIR FLOW FOR ELECTRIC HEAT

UNIT	HEATER KIT MODEL NUMBER	MINIMUM CFM
3 TON	EHK*-10	1250
	EHK*-15	1250
4 TON	EHK*-10	1300
	EHK*-15	1400
	EHK*-18	1400
5 TON	EHK*-10	1700
	EHK*-15	1700
	EHK*-20	1800



**ATTENTION INSTALLING PERSONNEL**

Use only the heater kit specified for each model as dictated by the table above.

# APPENDIX C UNIT DIMENSIONS

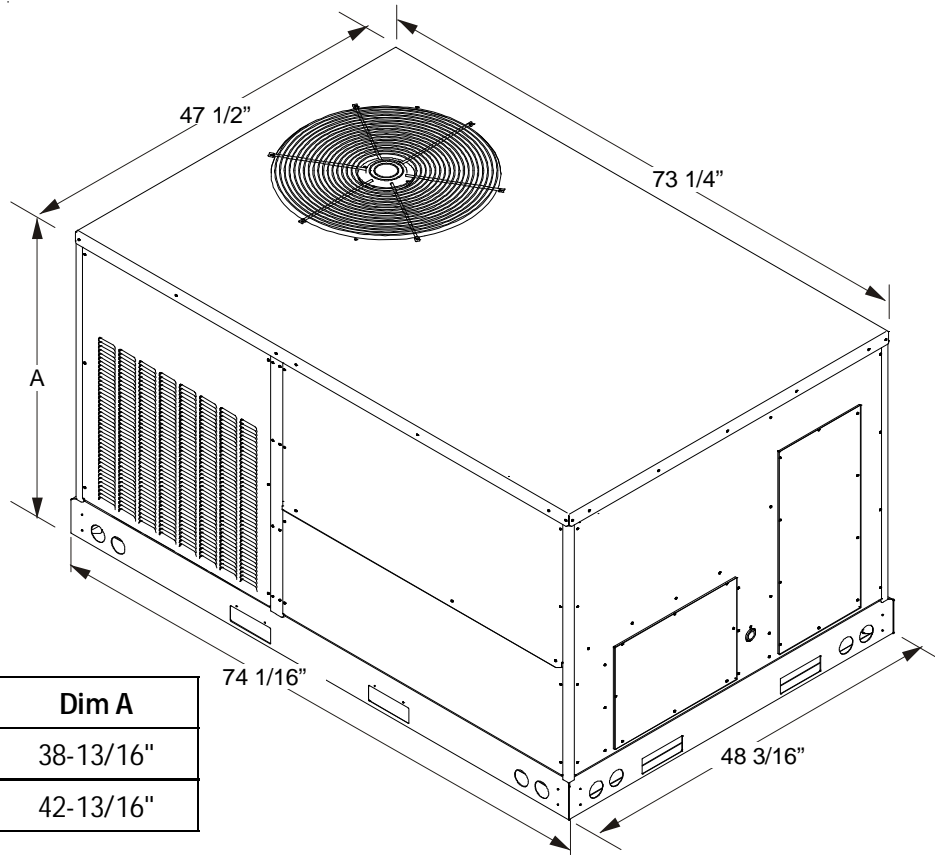

Model Size	Dim A
3 & 4 Ton	38-13/16"
5 Ton	42-13/16"

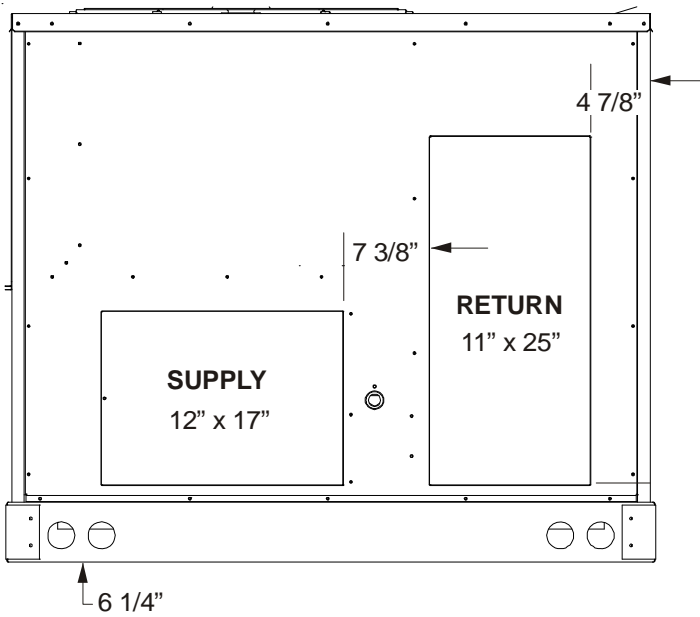

HORIZONTAL DISCHARGE

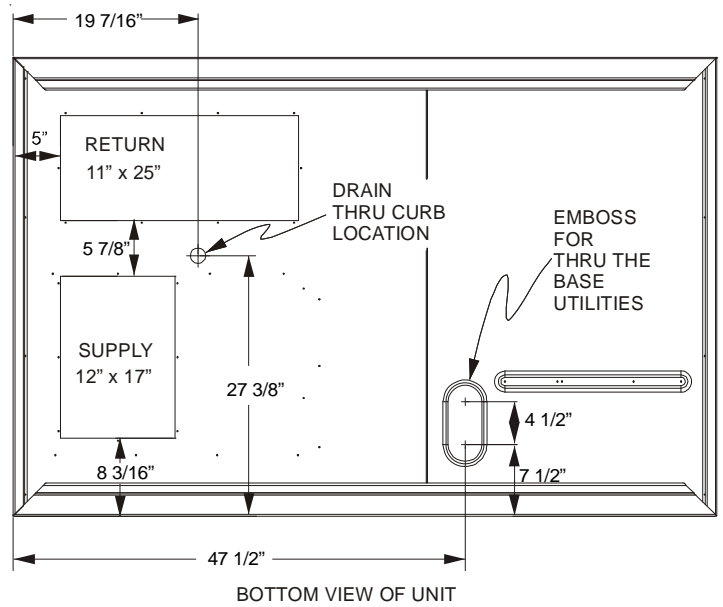

VERTICAL DISCHARGE

**WARNING**  
 HIGH VOLTAGE!  
 DISCONNECT ALL POWER BEFORE SERVICING OR INSTALLING THIS UNIT. MULTIPLE POWER SOURCES MAY BE PRESENT. FAILURE TO DO SO MAY CAUSE PROPERTY DAMAGE, PERSONAL INJURY OR DEATH.

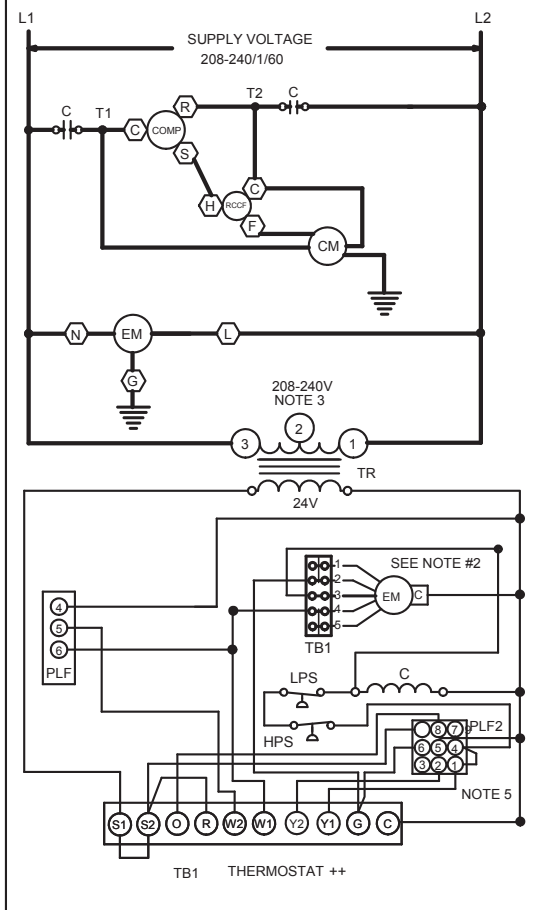
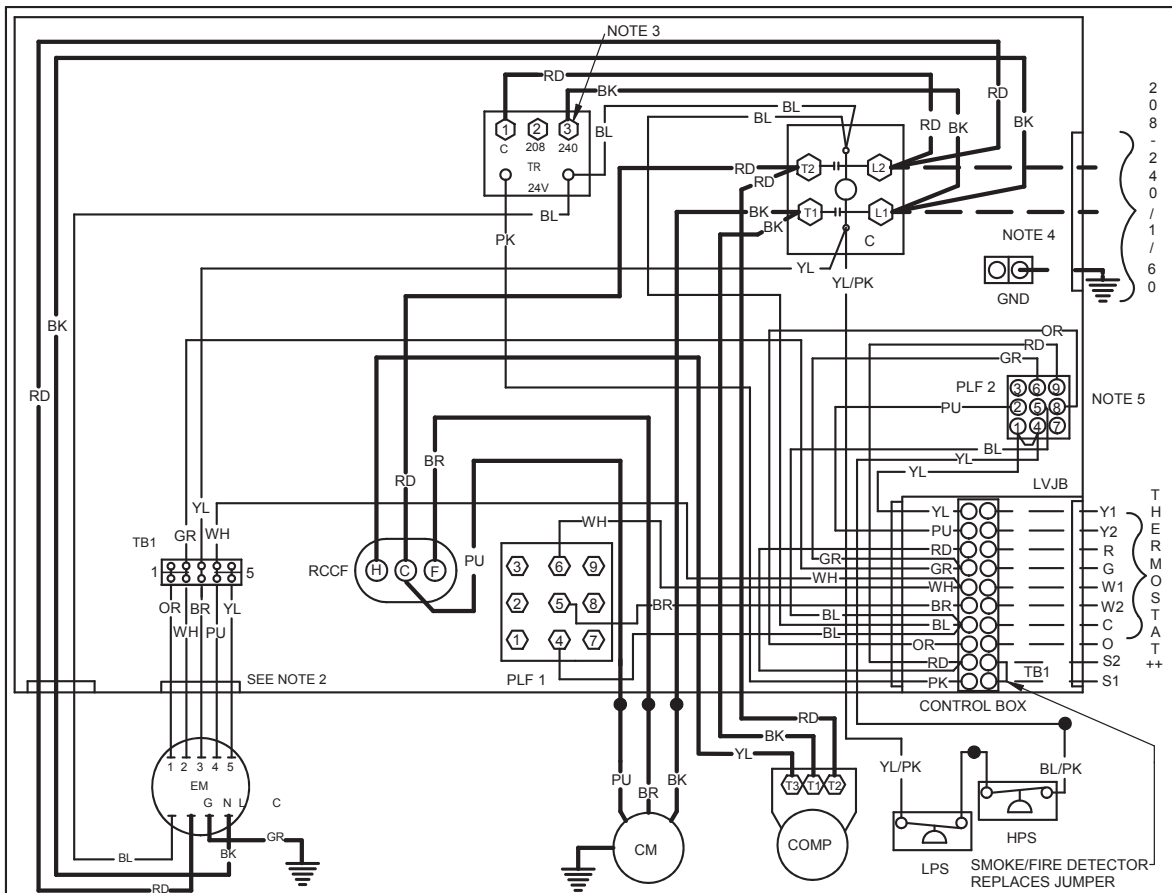

**COMPONENT LEGEND**

C	CONTACTOR
CM	CONDENSER MOTOR
COMP	COMPRESSOR
EM	EVAPORATOR MOTOR
GND	EQUIPMENT GROUND
LVJB	LOW VOLTAGE JUNCTION BOX
PLF	FEMALE PLUG / CONNECTOR
RCCF	RUN CAPACITOR FOR COMPRESSOR AND FAN
TB1	TERMINAL BLOCK (24V SIGNAL) TRANSFORMER
TR	TRANSFORMER

- NOTES:**
- REPLACEMENT WIRE MUST BE SAME SIZE AND TYPE INSULATION AS ORIGINAL (AT LEAST 105 C) USE COPPER CONDUCTOR ONLY.
  - TO CHANGE EVAPORATOR MOTOR SPEED MOVE WHITE AND YELLOW LEADS FROM "3" AND "4" TO "4" AND "5". IF BOTH LEADS ARE ENERGIZED, THE HIGHER SPEED SETTING IS USED.
  - FOR 208 VOLT TRANSFORMER OPERATION MOVE BLACK WIRE FROM TERMINAL 3 TO TERMINAL 2 ON TRANSFORMER.
  - USE COPPER CONDUCTORS ONLY  
++ USE N.E.C. CLASS 2 WIRE.
  - ECONOMIZER PLUG LOCATED IN RETURN AIR COMPARTMENT. REMOVE MALE PLUG AND ATTACH FEMALE PLUG TO ECONOMIZER ACCESSORY.
- SEE UNIT RATING PLATE FOR TYPE AND SIZE OF OVER CURRENT PROTECTION

JUNCTION		EQUIPMENT GROUND	
INTERNAL TO INTEGRATED CONTROL		FIELD GROUND	
PLUG CONNECTION		FIELD SPlice	
SWITCH (PRESS)		SWITCH (TEMP)	
OVERCURRENT PROT. DEVICE		IGNITER	

**FACTORY WIRING**

— LINE VOLTAGE  
 - - - LOW VOLTAGE  
 - - - - OPTIONAL HIGH VOLTAGE  
 - - - - - OPTIONAL LOW VOLTAGE

**FIELD WIRING**

--- HIGH VOLTAGE  
 - - - - LOW VOLTAGE

**WIRE CODE**

BK BLACK  
 BL BLUE  
 BR BROWN  
 GR GREEN  
 OR ORANGE  
 PK PINK  
 PU PURPLE  
 RD RED  
 WH WHITE  
 YL YELLOW  
 BL/PK BLUE WITH PINK STRIP  
 YL/PK YELLOW WITH PINK STRIP

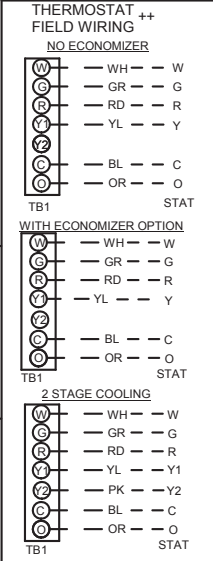

208-240/1/60 0140L02910-B

Wiring is subject to change. Always refer to the wiring diagram on the unit for the most up-to-date wiring.

**WARNING**  
 HIGH VOLTAGE!  
 DISCONNECT ALL POWER BEFORE SERVICING OR INSTALLING THIS UNIT. MULTIPLE POWER SOURCES MAY BE PRESENT. FAILURE TO DO SO MAY CAUSE PROPERTY DAMAGE, PERSONAL INJURY OR DEATH.

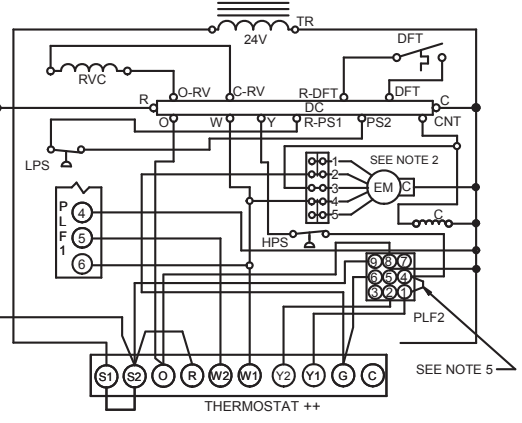
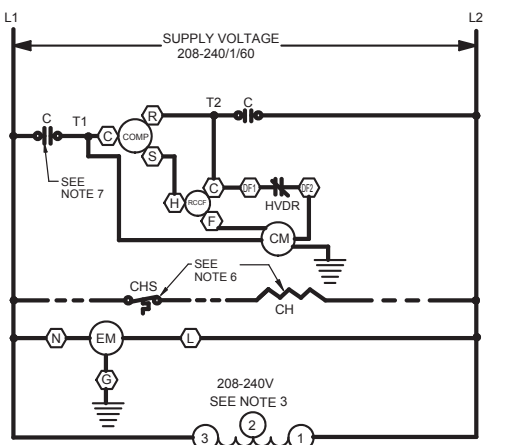
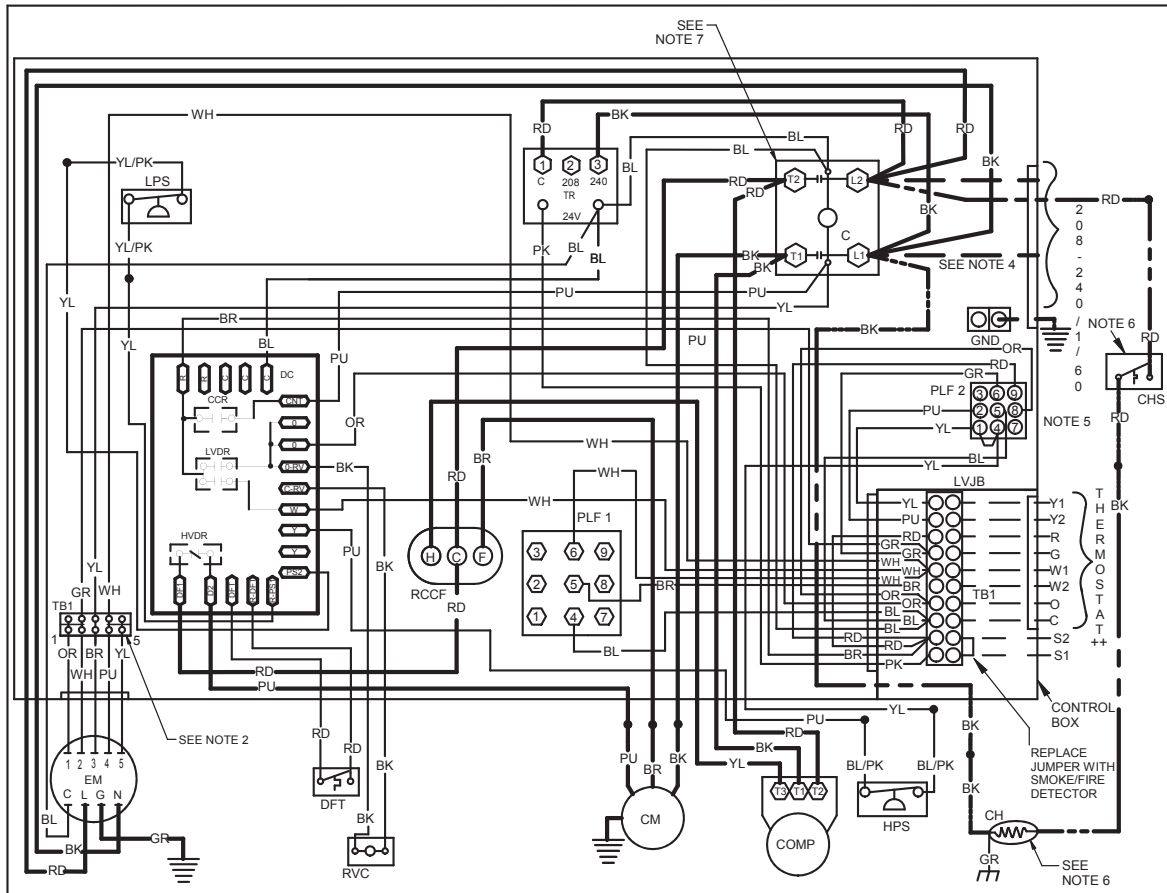

**COMPONENT LEGEND**

C	CONTACTOR
CCR	COMPRESSOR CONTACTOR RELAY
CH	CRANKCASE HEATER
CHS	CRANKCASE HEATER SWITCH
CM	CONDENSER MOTOR
COMP	COMPRESSOR
DC	DEFROST CONTROL
DFT	DEFROST THERMOSTAT
ECON	ECONOMIZER
EM	EVAPORATOR MOTOR
GND	EQUIPMENT GROUND
HPS	HIGH PRESSURE SWITCH
HVDR	HIGH VOLTAGE DEFROST RELAY
LPS	LOW PRESSURE SWITCH
LVDR	LOW VOLTAGE DEFROST RELAY
LVJB	LOW VOLTAGE JUNCTION BOX
PLF	FEMALE PLUG / CONNECTOR
RVC	REVERSING VALVE COIL
RCCF	RUN CAPACITOR FOR COMPRESSOR AND FAN
TB1	TERMINAL BLOCK (24V SIGNAL)
TR	TRANSFORMER

**NOTES:**

- REPLACEMENT WIRE MUST BE SAME SIZE AND TYPE INSULATION AS ORIGINAL (AT LEAST 105 C) USE COPPER CONDUCTOR ONLY.
- TO CHANGE EVAPORATOR MOTOR SPEED MOVE WHITE AND YELLOW LEADS FROM "3" AND "4" TO "4" AND "5". IF BOTH LEADS ARE ENERGIZED, THE HIGHER SPEED SETTING IS USED.
- FOR 208 VOLT TRANSFORMER OPERATION MOVE BLACK WIRE FROM TERMINAL 3 TO TERMINAL 2 ON TRANSFORMER.
- USE COPPER CONDUCTORS ONLY

++ USE N.E.C. CLASS 2 WIRE

ECONOMIZER PLUG LOCATED IN THE RETURN AIR COMPARTMENT. REMOVE MALE PLUG AND ATTACH FEMALE PLUG TO ECONOMIZER ACCESSORY.

CRANKCASE HEATER AND CRANKCASE HEATER SWITCH FACTORY EQUIPPED WHEN REQUIRED.

DOUBLE POLE CONTACTOR SHOWN. SINGLE POLE CONTACTOR COULD BE FACTORY EQUIPPED AS AN ALTERNATE CONFIGURATION.

SEE UNIT RATING PLATE FOR TYPE AND SIZE OF OVER CURRENT PROTECTION

**FACTORY WIRING**

- SOLID LINE: LINE VOLTAGE
- DASHED LINE: LOW VOLTAGE
- DOTTED LINE: OPTIONAL
- THICK DASHED LINE: HIGH VOLTAGE
- THIN DOTTED LINE: OPTIONAL LOW VOLTAGE

**FIELD WIRING**

- SOLID LINE: HIGH VOLTAGE
- DOTTED LINE: LOW VOLTAGE

**WIRE CODE**

- BK: BLACK
- BL: BLUE
- BR: BROWN
- GR: GREEN
- OR: ORANGE
- PK: PINK
- RD: RED
- PU: PURPLE
- YL: YELLOW
- WH: WHITE
- BL/PK: BLUE WITH PINK STRIP
- YL/PK: YELLOW WITH PINK STRIP

**THERMOSTAT ++ FIELD WIRING**

**NO ECONOMIZER**

WH	W
GR	G
RD	R
YL	Y
BL	C
OR	O

TB1 STAT

**WITH ECONOMIZER OPTION**

WH	W
GR	G
RD	R
YL	Y
BL	C
OR	O

TB1 STAT

**2 STAGE COOLING**

WH	W
GR	G
RD	R
YL	Y1
PK	Y2
BL	C
OR	O

TB1 STAT

208-240/1/60 0140L02907-B

Wiring is subject to change. Always refer to the wiring diagram on the unit for the most up-to-date wiring.

**HIGH VOLTAGE!**  
 DISCONNECT ALL POWER BEFORE SERVICING OR INSTALLING THIS UNIT. MULTIPLE POWER SOURCES MAY BE PRESENT. FAILURE TO DO SO MAY CAUSE PROPERTY DAMAGE, PERSONAL INJURY OR DEATH.

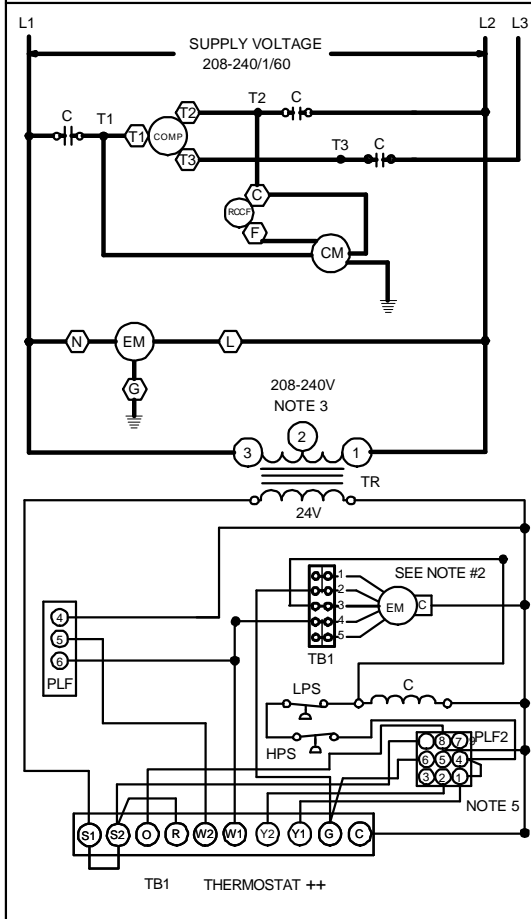
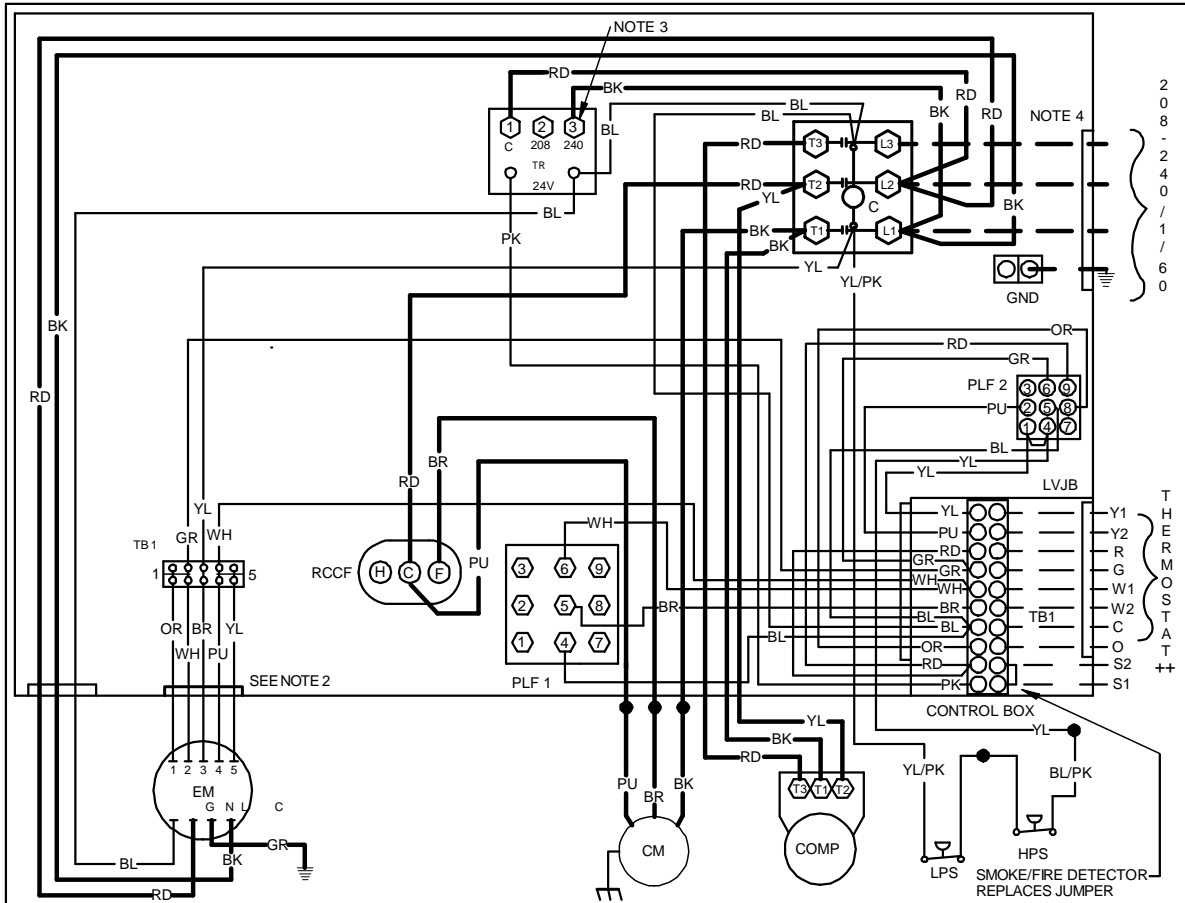

**COMPONENT LEGEND**

C	CONTACTOR
CM	CONDENSER MOTOR
COMP	COMPRESSOR
EM	EVAPORATOR MOTOR
GND	EQUIPMENT GROUND
HPS	HIGH PRESSURE SWITCH
LPS	LOW PRESSURE SWITCH
LVJB	LOW VOLTAGE JUNCTION BOX
PLF	FEMALE PLUG / CONNECTOR
RCCF	RUN CAPACITOR FOR COMPRESSOR FAN
TB1	TERMINAL BLOCK (24V SIGNAL)
TR	TRANSFORMER

**NOTES:**

- REPLACEMENT WIRE MUST BE SAME SIZE AND TYPE INSULATION AS ORIGINAL (AT LEAST 105°Q USE COPPER CONDUCTOR ONLY).
- TO CHANGE EVAPORATOR MOTOR SPEED MOVE WHITE AND YELLOW LEADS FROM "3" AND "4" TO "4" AND "5". IF BOTH LEADS ARE ENERGIZED, THE HIGHER SPEED SETTING IS USED.
- FOR 208VOLT TRANSFORMER OPERATION MOVE BLACK WIRE FROM TERMINAL 3 TO TERMINAL 2 ON TRANSFORMER.
- USE COPPER CONDUCTORS ONLY
- ECONOMIZER PLUG LOCATED IN RETURN AIR COMPARTMENT. REMOVE MALE PLUG AND ATTACH FEMALE PLUG TO ECONOMIZER ACCESSORY.  
SEE UNIT RATING PLATE FOR TYPE AND SIZE OF OVER CURRENT PROTECTION

JUNCTION TERMINAL	EQUIPMENT GROUND
INTERNAL TO INTEGRATED CONTROL	FIELD GROUND
PLUG CONNECTION	FIELD SPLICE
SWITCH (PRESS.)	SWITCH (TEMP)
OVERCURRENT PROT. DEVICE	IGNITER

**FACTORY WIRING**

- SOLID LINE: LINE VOLTAGE
- DASHED LINE: LOW VOLTAGE
- THICK DASHED LINE: OPTIONAL HIGH VOLTAGE
- THIN DASHED LINE: OPTIONAL LOW VOLTAGE

**FIELD WIRING**

- THICK DASHED LINE: HIGH VOLTAGE
- THIN DASHED LINE: LOW VOLTAGE

**WIRE CODE**

BK BLACK  
BL BLUE  
BR BROWN  
GR GREEN  
OR ORANGE  
PK PINK  
PU PURPLE  
RD RED  
WH WHITE  
YL YELLOW  
YL/PK BLUE WITH PINK STRIP  
YL/PK YELLOW WITH PINK STRIP

**THERMOSTAT FIELD WIRING**

**NO ECONOMIZER**

W	---	WH	---	W
G	---	GR	---	G
R	---	RD	---	R
Y	---	YL	---	Y
C	---	BL	---	C
O	---	OR	---	O

TB1 STAT

**WITH ECONOMIZER OPTION**

W	---	WH	---	W
G	---	GR	---	G
R	---	RD	---	R
Y	---	YL	---	Y
C	---	BL	---	C
O	---	OR	---	O

TB1 STAT

**2 STAGE COOLING**

W	---	WH	---	W
G	---	GR	---	G
R	---	RD	---	R
Y	---	YL	---	Y
C	---	PK	---	C
O	---	BL	---	O
STAT	---	OR	---	STAT

208-240/3/60 0140L02911-B

Wiring is subject to change. Always refer to the wiring diagram on the unit for the most up-to-date wiring.

**HIGH VOLTAGE!**  
 DISCONNECT ALL POWER BEFORE SERVICING OR INSTALLING THIS UNIT. MULTIPLE POWER SOURCES MAY BE PRESENT. FAILURE TO DO SO MAY CAUSE PROPERTY DAMAGE, PERSONAL INJURY OR DEATH.

**WARNING**

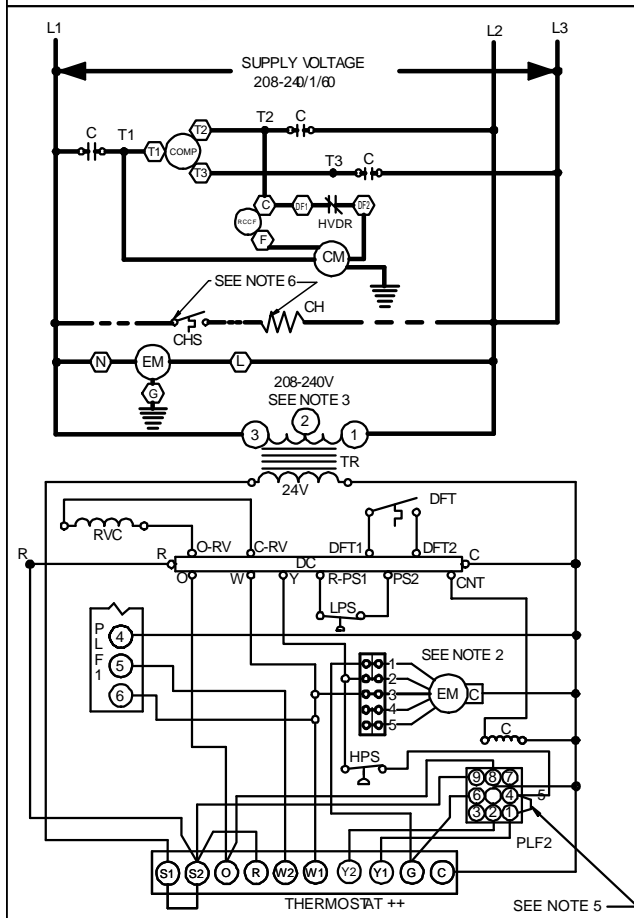
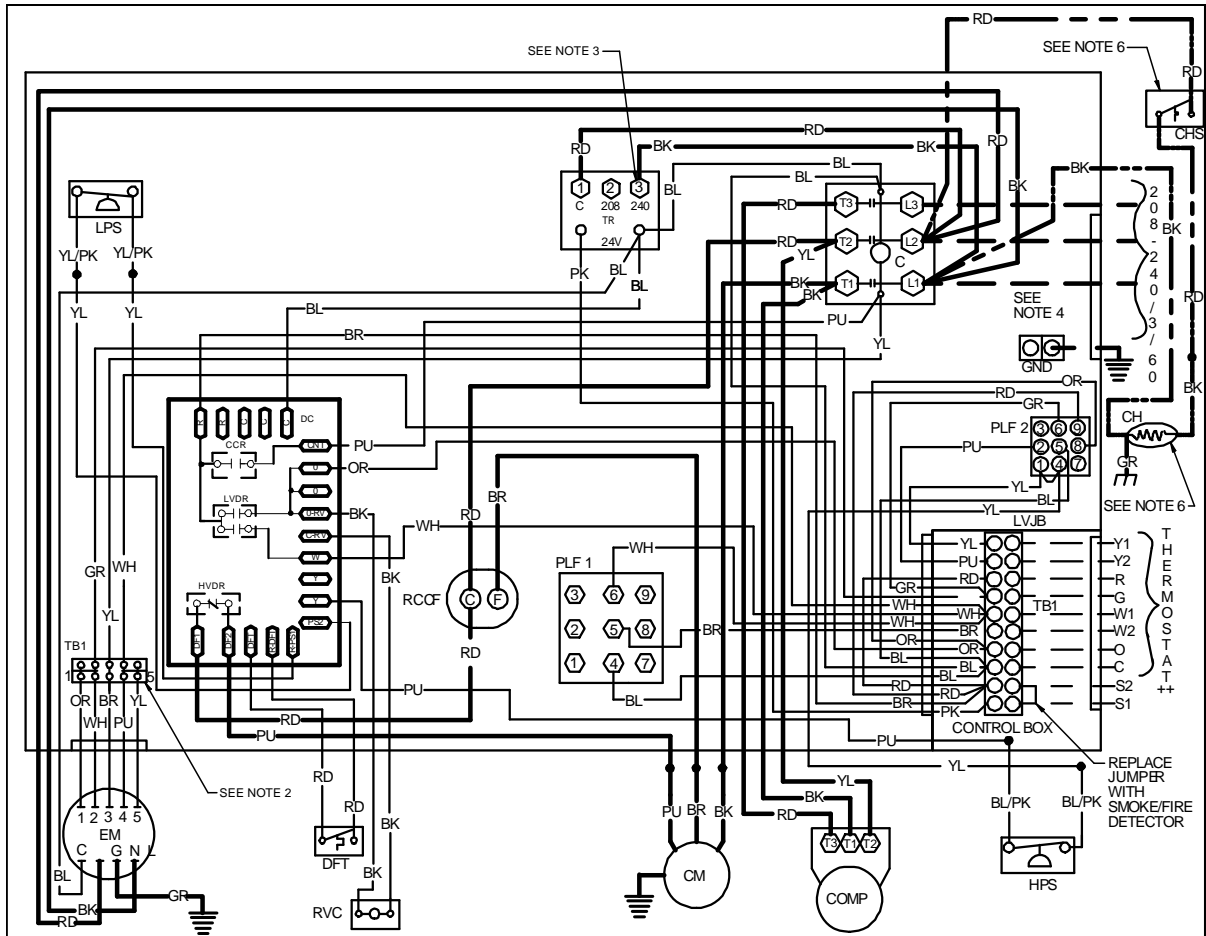

**COMPONENT LEGEND**

- C CONTACTOR
- CCR COMPRESSOR CONTACTOR RELAY
- CH CRANKCASE HEATER
- CHS CRANKCASE HEATER SWITCH
- CM CONDENSER MOTOR
- COMP COMPRESSOR
- DFT DEFROST CONTROL
- DFT DEFROST THERMOSTAT
- ECON ECONOMIZER
- EM EVAPORATOR MOTOR
- GND EQUIPMENT GROUND
- HPS HIGH PRESSURE SWITCH
- HVDR HIGH VOLTAGE DEFROST RELAY
- LPS LOW PRESSURE SWITCH
- LVDR LOW VOLTAGE DEFROST RELAY
- LVJB LOW VOLTAGE JUNCTION BOX
- PLF FEMALE PLUG / CONNECTOR
- RVC REVERSING VALVE COIL
- RCCF RUN CAPACITOR FOR CONDENSER FAN
- TB1 TERMINAL BLOCK (24V SIGNAL)
- TR TRANSFORMER
- RV REVERSING VALVE

**NOTES:**

- REPLACEMENT WIRE MUST BE SAME SIZE AND TYPE INSULATION AS ORIGINAL (AT LEAST 105°C) USE COPPER CONDUCTOR ONLY.
- TO CHANGE EVAPORATOR MOTOR SPEED MOVE WHITE AND YELLOW LEADS FROM '3' AND '4' TO '4' AND '5'. IF BOTH LEADS ARE ENERGIZED, THE HIGHER SPEED SETTING IS USED.
- FOR 208 VOLT TRANSFORMER OPERATION MOVE BLACK WIRES FROM TERMINAL 3 TO TERMINAL 2 ON TRANSFORMER.
- USE COPPER CONDUCTORS ONLY
- USE N.E.C. CLASS 2 WIRE
- ECONOMIZER PLUG LOCATED IN THE RETURN AIR COMPARTMENT. REMOVE MALE PLUG AND ATTACH FEMALE PLUG TO ECONOMIZER ACCESSORY.
- CRANKCASE HEATER AND CRANKCASE HEATER SWITCH FACTORY EQUIPPED WHEN REQUIRED. SEE UNIT RATING PLATE FOR TYPE AND SIZE OF OVER CURRENT PROTECTION

**WIRE CODE**

- BK BLACK
- BL BLUE
- BR BROWN
- GR GREEN
- RD RED
- PK PINK
- PU PURPLE
- OR ORANGE
- WH WHITE
- YL YELLOW

**FACTORY WIRING**

- SOLID LINE: LINE VOLTAGE
- DASHED LINE: LOW VOLTAGE
- DOTTED LINE: OPTIONAL HIGH VOLTAGE
- DASH-DOTTED LINE: OPTIONAL LOW VOLTAGE

**FIELD WIRING**

- SOLID LINE: HIGH VOLTAGE
- DASHED LINE: LOW VOLTAGE

**THERMOSTAT ++ FIELD WIRING**

**NO ECONOMIZER**

- WH --- W
- GR --- G
- RD --- R
- YL --- Y
- OR --- O

**WITH ECONOMIZER OPTION**

- WH --- W
- GR --- G
- RD --- R
- YL --- Y
- PK --- Y1
- BL --- Y2
- OR --- O

**2 STAGE COOLING**

- WH --- W
- GR --- G
- RD --- R
- YL --- Y
- PK --- Y1
- BL --- Y2
- OR --- O

**SYMBOLS:**

- JUNCTION: T
- TERMINAL: ⊥
- INTERNAL TO INTEGRATED CONTROL: ⊕
- PLUG CONNECTION: ⊕
- SWITCH (PRESS.): S
- OVERCURRENT PROT. DEVICE: ⚡
- EQUIPMENT GROUND: ⚡
- FIELD GROUND: ⊕
- FIELD SPICE: ⊕
- SWITCH (TEMP.): S
- IGNITER: ⚡

208-240/3/60 0140L02908-B

Wiring is subject to change. Always refer to the wiring diagram on the unit for the most up-to-date wiring.



## **WIRING DIAGRAMS FOR MODELS WITH DDC CONTROLS**

*For complete information and installation instructions for models with DDC controls,  
see manual DK-DDC-TGD-XXX*

**WARNING**

**HIGH VOLTAGE!**  
 DISCONNECT ALL POWER BEFORE SERVICING OR INSTALLING THIS UNIT. MULTIPLE POWER SOURCES MAY BE PRESENT. FAILURE TO DO SO MAY CAUSE PROPERTY DAMAGE, PERSONAL INJURY OR DEATH.

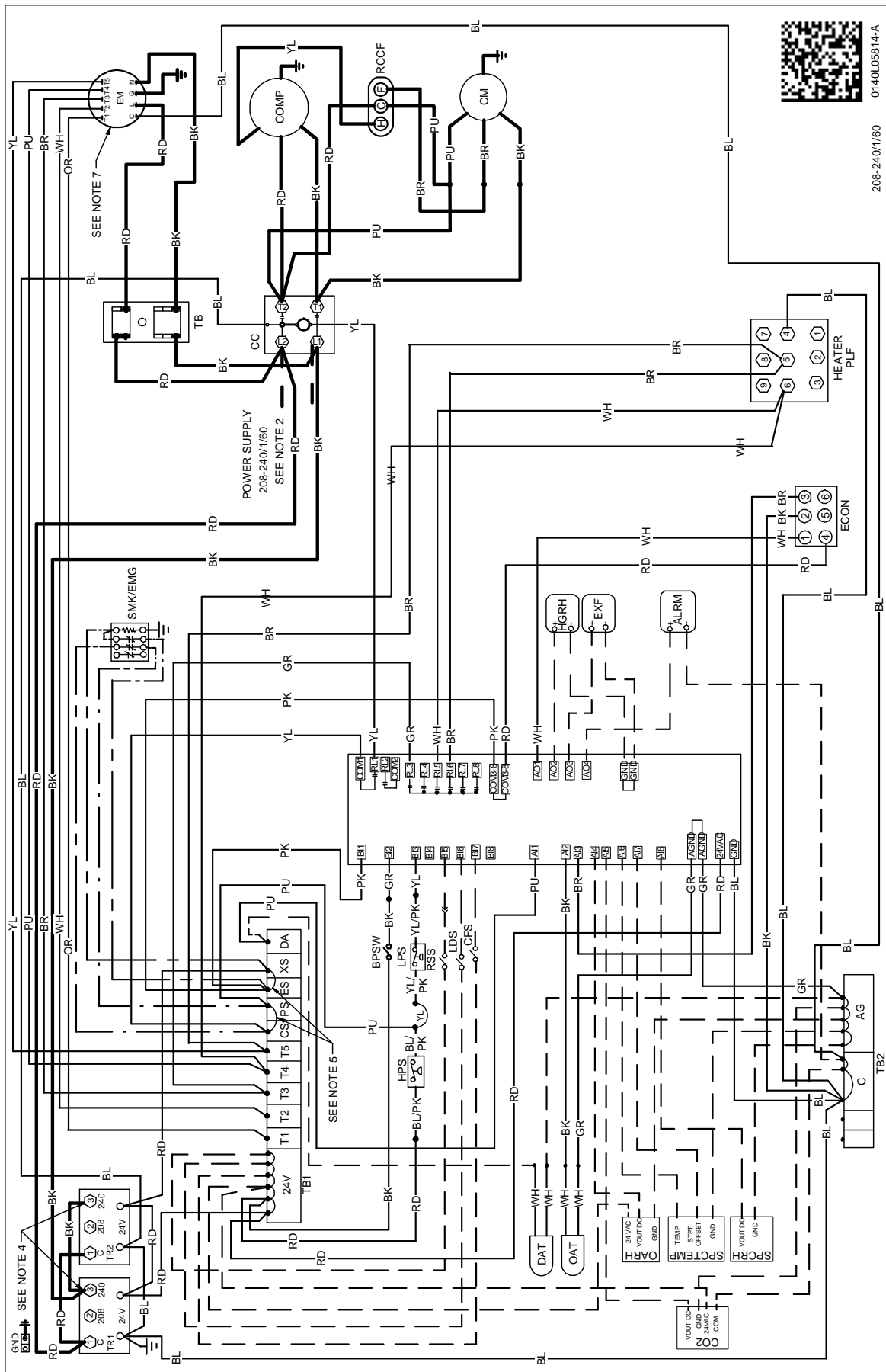

208-240/1/60 0140L05614-A

Wiring is subject to change. Always refer to the wiring diagram on the unit for the most up-to-date wiring.



**WARNING**

**HIGH VOLTAGE!**  
**DISCONNECT ALL POWER BEFORE SERVICING OR INSTALLING THIS UNIT. MULTIPLE POWER SOURCES MAY BE PRESENT. FAILURE TO DO SO MAY CAUSE PROPERTY DAMAGE, PERSONAL INJURY OR DEATH.**

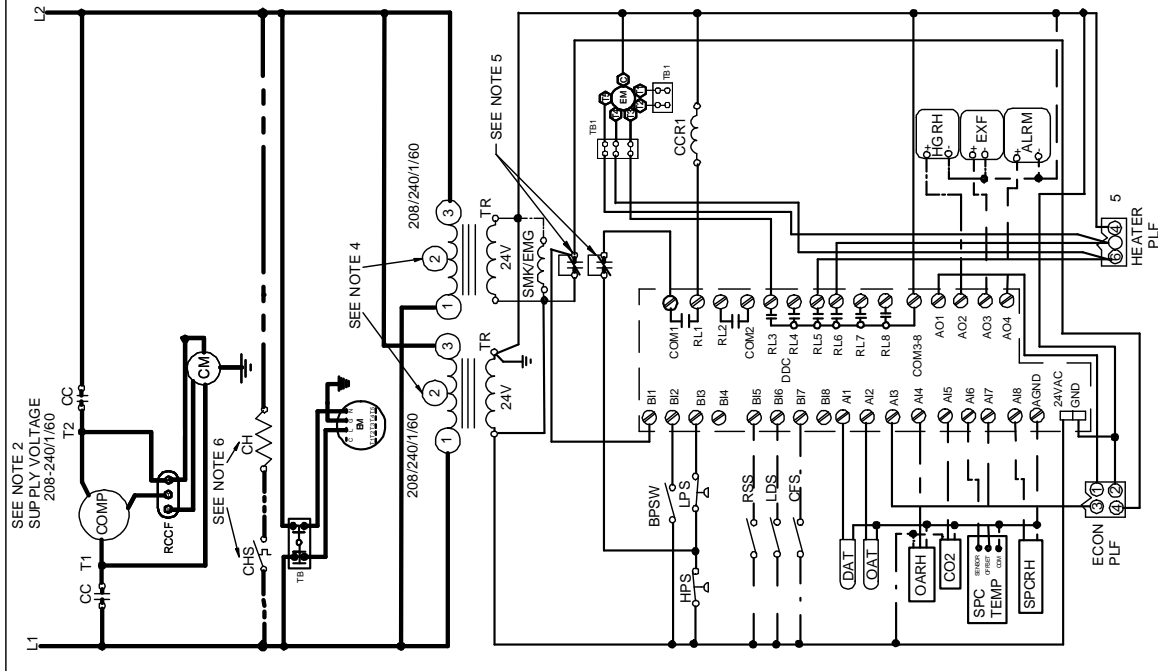

COMPONENT LEGEND	COMPONENT LEGEND
EM EVAPORATOR MOTOR	AGND DC GROUND FOR ANALOG
EXF EXHAUST FAN	AO 4 ANALOG OUTPUTS
GND EQUIPMENT GROUND	AI 8 ANALOG INPUTS
HGRH HOT GAS REHEAT	ALRM ALARM
HPS HIGH PRESSURE SWITCH	BI 8 BINARY INPUTS
LDS LOW PRESSURE SWITCH	BL BLOWER LOW SPEED
LP LOW PRESSURE SWITCH	BPSW BLOWER PROVING SWITCH
LOA OUTDOOR AIR RELATIVE HUMIDITY	CC COMPRESSOR CONTACTOR RELAY
LOA2 OUTDOOR AIR RELATIVE HUMIDITY	CCR CLOGGED FILTER SWITCH
PLF FEMALE PLUG / CONNECTOR	CHS CRANKCASE HEATER SWITCH
PS RUN CAPACITOR FOR CONDENSER FAN	CM CONDENSER MOTOR
RCCF RELAY	COM COMMON ("C" ON TB2)
RSS REMOTE START STOP	COMP COMPRESSOR
RVC REVERSING VALVE COIL	CS COM1 AND SMOKE DETECTOR
SAT/DAT SUPPLY / DISCHARGE AIR TEMPERATURE	DFT DEFROST THERMOSTAT
SMK/ENG SMOKE OR EMERGENCY SHUTDOWN	ECON ECONOMIZER
SPC SPACE TEMPERATURE	
SPCRH SPACE RELATIVE HUMIDITY	
T1-T5 MOTOR SPEED TAPS 1-5	
TB1-2 (DIRECT DRIVEN MOTOR ONLY)	
TR1-2 TERMINAL BLOCK (24V SIGNAL)	
XS 24 VAC TRANSFORMER & SMOKE DETECTOR	

FACTORY WIRING	NOTES:
— LINE VOLTAGE	1. REPLACEMENT WIRE MUST BE SAME SIZE AND TYPE INSULATION AS ORIGINAL (AT LEAST 105°C) USE COPPER CONDUCTOR ONLY.
— OPTIONAL HIGH VOLTAGE	2. USE COPPER CONDUCTORS ONLY
— FIELD WIRING	3. ECONOMIZER PLUG LOCATED IN THE RETURN AIR COMPARTMENT. REMOVE MALE PLUG AND ATTACH FEMALE PLUG TO THE ECONOMIZER ACCESSORY.
— HIGH VOLTAGE	4. FOR 208 VOLT TRANSFORMER OPERATION MOVE BLACK WIRE FROM TERMINAL (3) TO TERMINAL (2) ON TRANSFORMER.
— LOW VOLTAGE	5. REMOVE JUMPER IF SMOKE DETECTOR OR EMERGENCY SHUTDOWN DEVICE IS INSTALLED.
WIRE CODE	6. CRANKCASE HEATER AND CRANKCASE HEATER SWITCH FACTORY EQUIPPED WHEN REQUIRED.
BK BLACK	7. FOR DIFFERENT THAN FACTORY SPEED TAP, CHANGE COOLING SPEED AT MOTOR T1, T2 AND T3. SPEED TAP TERMINATIONS SHOWN ON DIAGRAM ARE REPRESENTATIVE BUT ACTUAL FACTORY SETTINGS MAY BE DIFFERENT BASED ON THE HEATING VALUE OF THE UNIT.
BL BLUE	COOLING SPEED (GREEN AND BROWN)
BR BROWN	T3 - LOW SPEED
GR GREEN	T4 - HIGH SPEED
OR ORANGE	HEATING SPEED (WHITE)
PU PURPLE	T1 - LOW SPEED
RD RED	T2 - MED SPEED
WH WHITE	T5 - HIGH SPEED
YL/YLW YELLOW WITH PINK STRIPE	
Y/PK YELLOW WITH PINK STRIPE	

SCHEMATIC SYMBOL	SEE UNIT RATING PLATE FOR TYPE AND SIZE OF OVER CURRENT PROTECTION
— FIELD GROUND	
— FIELD SPLICE	
— IGNITER	
— JUNCTION	
— OVERCURRENT PROT. DEVICE	
— PLUG CONNECTION	
— SWITCH (PRESS)	
— SWITCH (TEMP)	
— TERMINAL	



208-240/1/60  
0140L09854-A

Wiring is subject to change. Always refer to the wiring diagram on the unit for the most up-to-date wiring.

**WARNING**

**HIGH VOLTAGE!**  
 DISCONNECT ALL POWER BEFORE SERVICING OR INSTALLING THIS UNIT. MULTIPLE POWER SOURCES MAY BE PRESENT. FAILURE TO DO SO MAY CAUSE PROPERTY DAMAGE, PERSONAL INJURY OR DEATH.

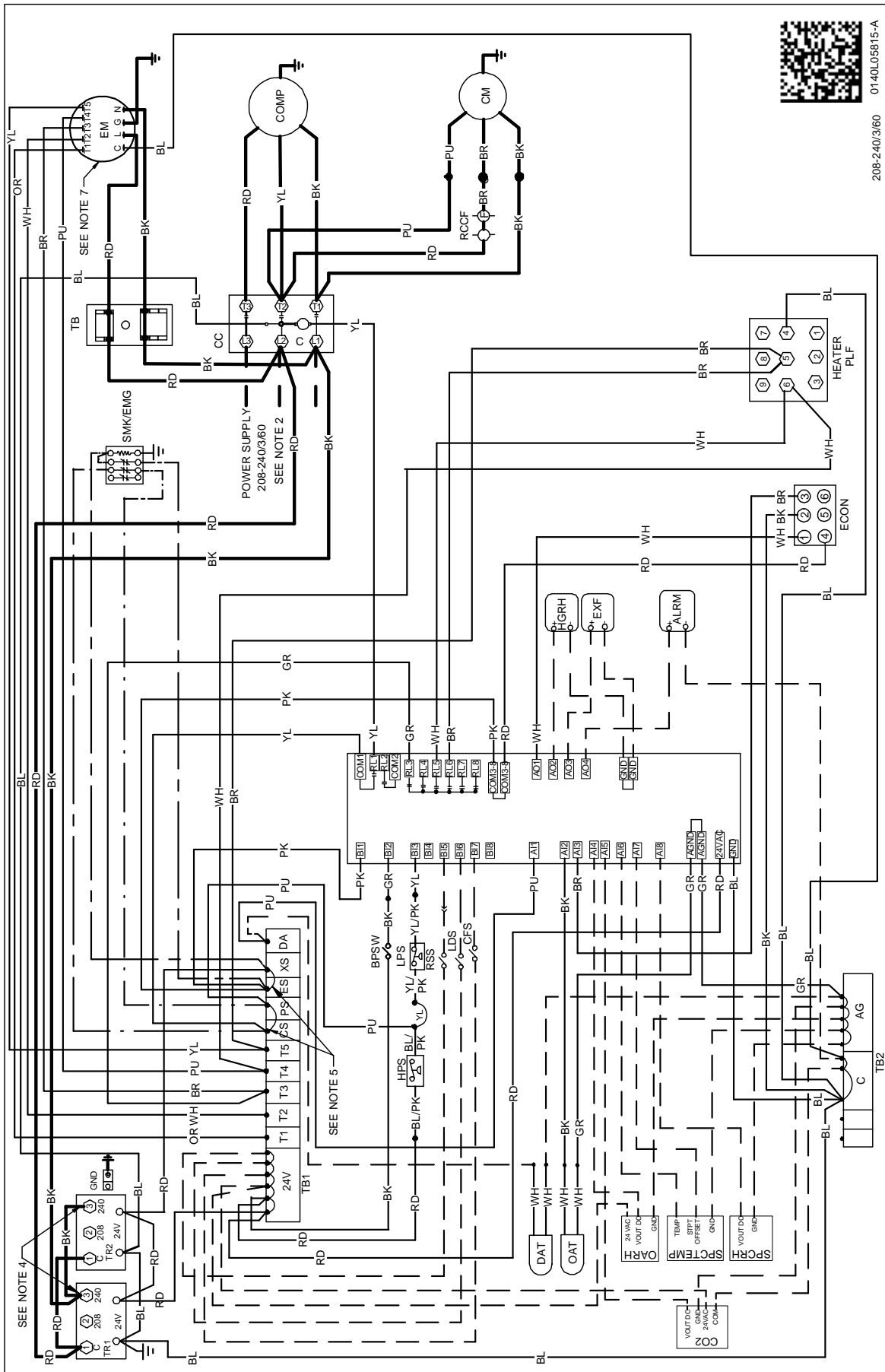

0140L05815-A  
 208-240/3/60

Wiring is subject to change. Always refer to the wiring diagram on the unit for the most up-to-date wiring.

**WARNING**

**HIGH VOLTAGE!**  
DISCONNECT ALL POWER BEFORE SERVICING OR INSTALLING THIS UNIT. MULTIPLE POWER SOURCES MAY BE PRESENT. FAILURE TO DO SO MAY CAUSE PROPERTY DAMAGE, PERSONAL INJURY OR DEATH.

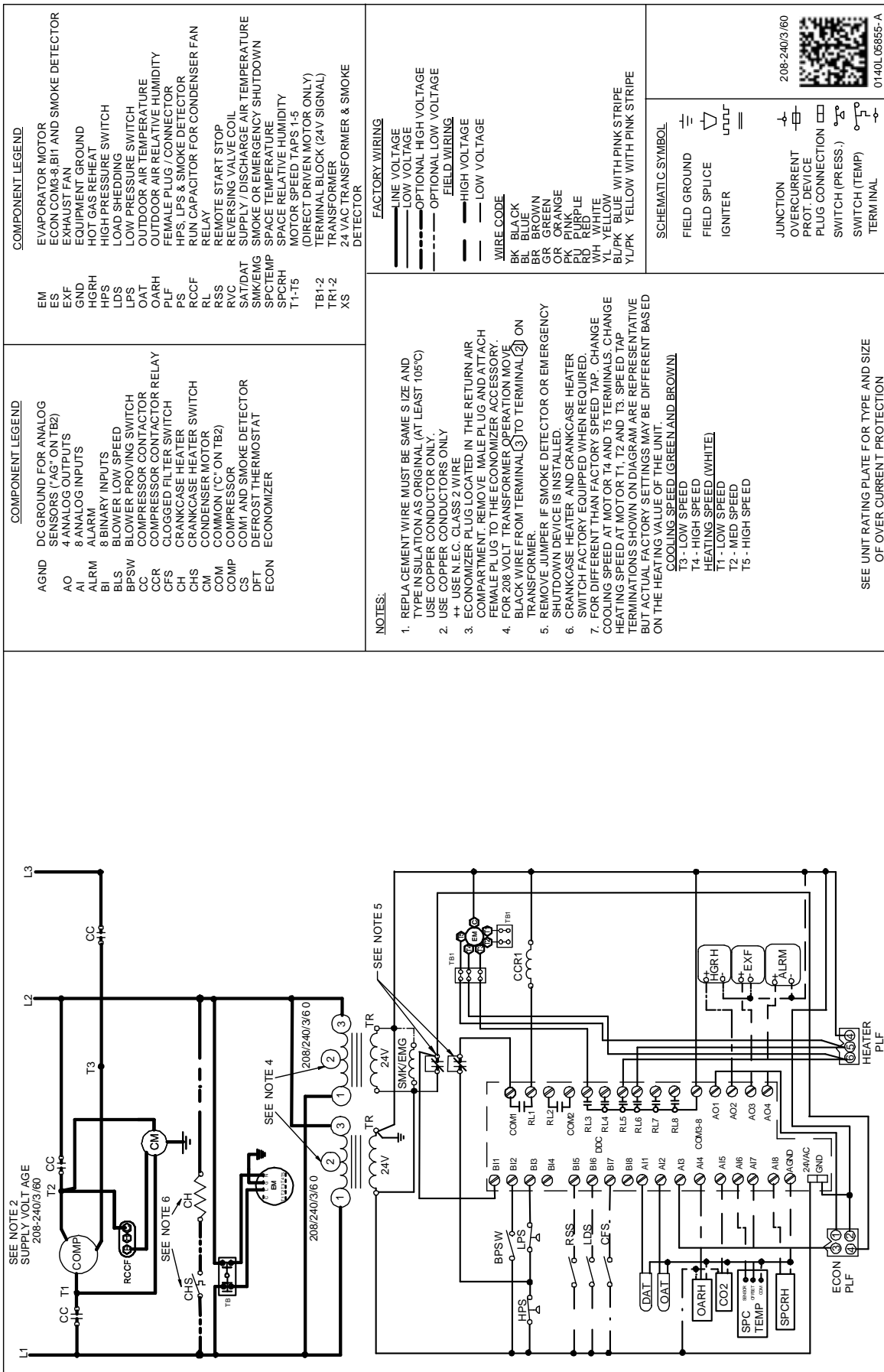

COMPONENT LEGEND	
EM	EVAPORATOR MOTOR
ES	ECON COMB-3 BIT AND SMOKE DETECTOR
EXF	EXHAUST FAN
GND	EXHAUST FAN GROUND
HGRH	HOT GAS REHEAT
HPS	HIGH PRESSURE SWITCH
LDS	LOAD SHEDDING
LPS	LOW PRESSURE SWITCH
OAT	OUTDOOR AIR TEMPERATURE
OARH	OUTDOOR AIR RELATIVE HUMIDITY
PLF	FEMALE PLUG / CONNECTOR
PS	HPS, LPS & SMOKE DETECTOR
RCCF	RUN CAPACITOR FOR CONDENSER FAN RELAY
RL	REVERSE START STOP
RSS	REVERSING VALVE COIL
RVC	SUPPLY / DISCHARGE AIR TEMPERATURE
SAT/EMG	SMOKE OR EMERGENCY SHUTDOWN
SPCTEMP	SPACE TEMPERATURE
SPCRH	SPACE RELATIVE HUMIDITY
T1-T5	MOTOR SPEED TAPS 1-5
TB1-2	(DIRECT DRIVEN MOTOR ONLY)
TR1-2	TRANSFORMER
XS	24VAC TRANSFORMER & SMOKE DETECTOR

COMPONENT LEGEND	
AGND	DC GROUND FOR ANALOG
AO	SENSORS ("AG" ON TB2)
AI	4 ANALOG OUTPUTS
ALRM	ALARM
BI	8 BINARY INPUTS
BLS	BLOWER LOW SPEED
BPSW	BLOWER PROVING SWITCH
CC	COMPRESSOR CONTACTOR
CCR	COMPRESSOR CONTACTOR RELAY
CFS	CLOGGED FILTER SWITCH
CH	CRANKCASE HEATER
CHS	CRANKCASE HEATER SWITCH
CM	CONDENSER MOTOR
COMP	COMMON ("C" ON TB2)
COMP	COMPRESSOR
CS	COM1 AND SMOKE DETECTOR
DFT	DEFROST THERMOSTAT
ECON	ECONOMIZER

FACTORY WIRING	
—	LINE VOLTAGE
—	LOW VOLTAGE
—	OPTIONAL HIGH VOLTAGE
—	OPTIONAL LOW VOLTAGE
FIELD WIRING	
—	HIGH VOLTAGE
—	LOW VOLTAGE

- NOTES:**
- REPLACEMENT WIRE MUST BE SAME SIZE AND TYPE IN SULATION AS ORIGINAL (AT LEAST 105°C) USE COPPER CONDUCTORS ONLY.
  - USE COPPER CONDUCTORS ONLY.
  - ECONOMIZER PLUG LOCATED IN THE RETURN AIR COMPARTMENT. REMOVE MALE PLUG AND ATTACH FEMALE PLUG TO THE ECONOMIZER ACCESSORY.
  - FOR 208 VOLT TRANSFORMER OPERATION MOVE BLACK WIRE FROM TERMINAL ③ TO TERMINAL ② ON TRANSFORMER.
  - REMOVE JUMPER IF SMOKE DETECTOR OR EMERGENCY SHUTDOWN DEVICE IS INSTALLED.
  - CRANKCASE HEATER AND CRANKCASE HEATER SWITCH FACTORY EQUIPPED WHEN REQUIRED.
  - FOR DIFFERENT THAN FACTORY SPEED TAP. CHANGE COOLING SPEED AT MOTOR T4 AND T5 TERMINALS. CHANGE HEATING SPEED AT MOTOR T1, T2 AND T3. SPEED TAP TERMINATIONS SHOWN ON DIAGRAM ARE REPRESENTATIVE BUT ACTUAL FACTORY SETTINGS MAY BE DIFFERENT BASED ON THE HEATING VALUE OF THE UNIT.

SCHEMATIC SYMBOL	
	FIELD GROUND
	FIELD SPLICE
	IGNITER
	JUNCTION
	OVERCURRENT PROT. DEVICE
	PLUG CONNECTION
	SWITCH (PRESS.)
	SWITCH (TEMP)
	TERMINAL

SEE UNIT RATING PLATE FOR TYPE AND SIZE OF OVER CURRENT PROTECTION

208-240/3/60

0140L06855-A

Wiring is subject to change. Always refer to the wiring diagram on the unit for the most up-to-date wiring.

**WARNING**

**HIGH VOLTAGE!**  
 DISCONNECT ALL POWER BEFORE SERVICING OR INSTALLING THIS UNIT. MULTIPLE POWER SOURCES MAY BE PRESENT. FAILURE TO DO SO MAY CAUSE PROPERTY DAMAGE, PERSONAL INJURY OR DEATH.

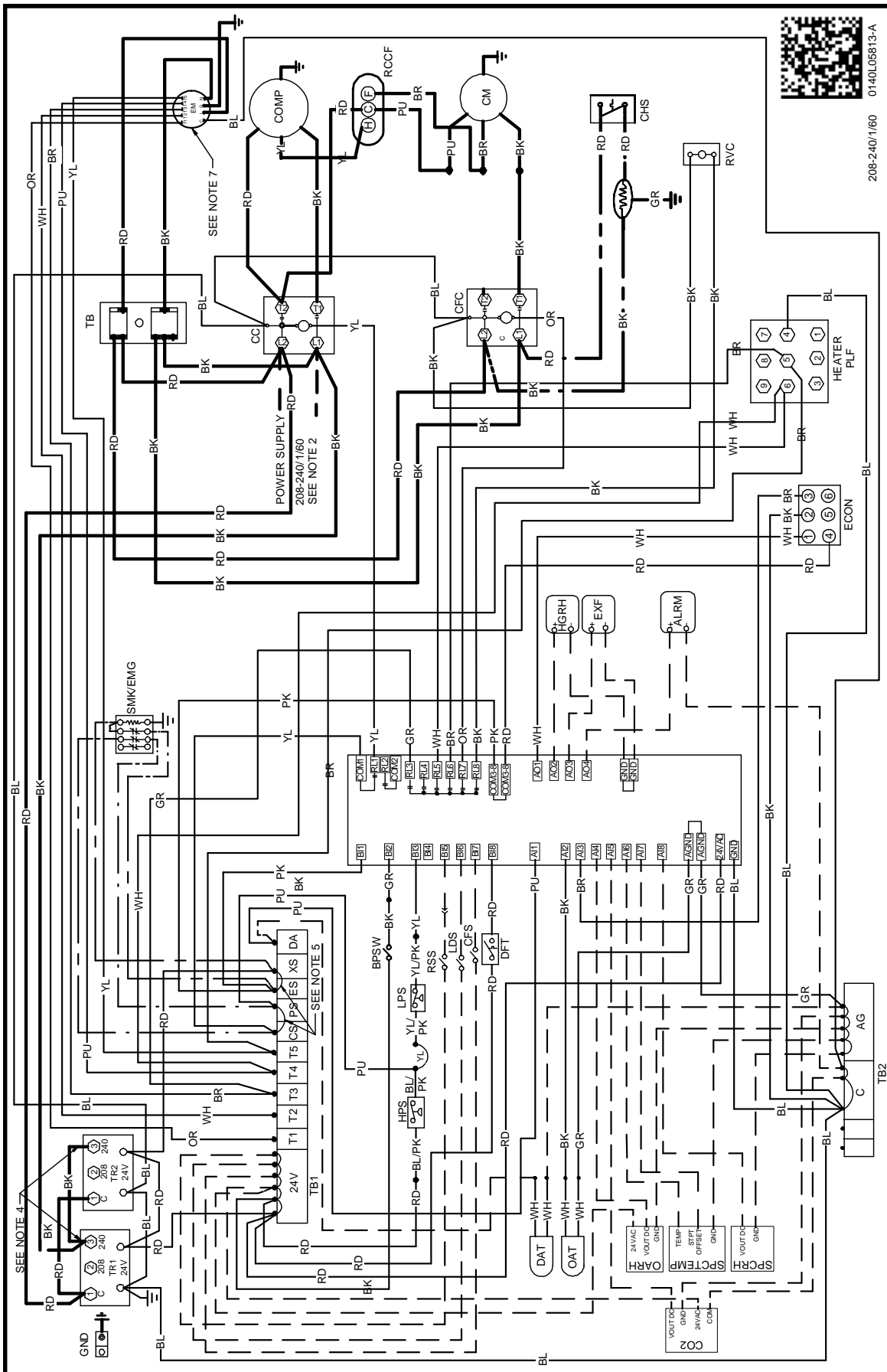

Wiring is subject to change. Always refer to the wiring diagram on the unit for the most up-to-date wiring.



**HIGH VOLTAGE!**  
**DISCONNECT ALL POWER BEFORE SERVICING OR INSTALLING THIS UNIT. MULTIPLE POWER SOURCES MAY BE PRESENT. FAILURE TO DO SO MAY CAUSE PROPERTY DAMAGE, PERSONAL INJURY OR DEATH.**

**WARNING**

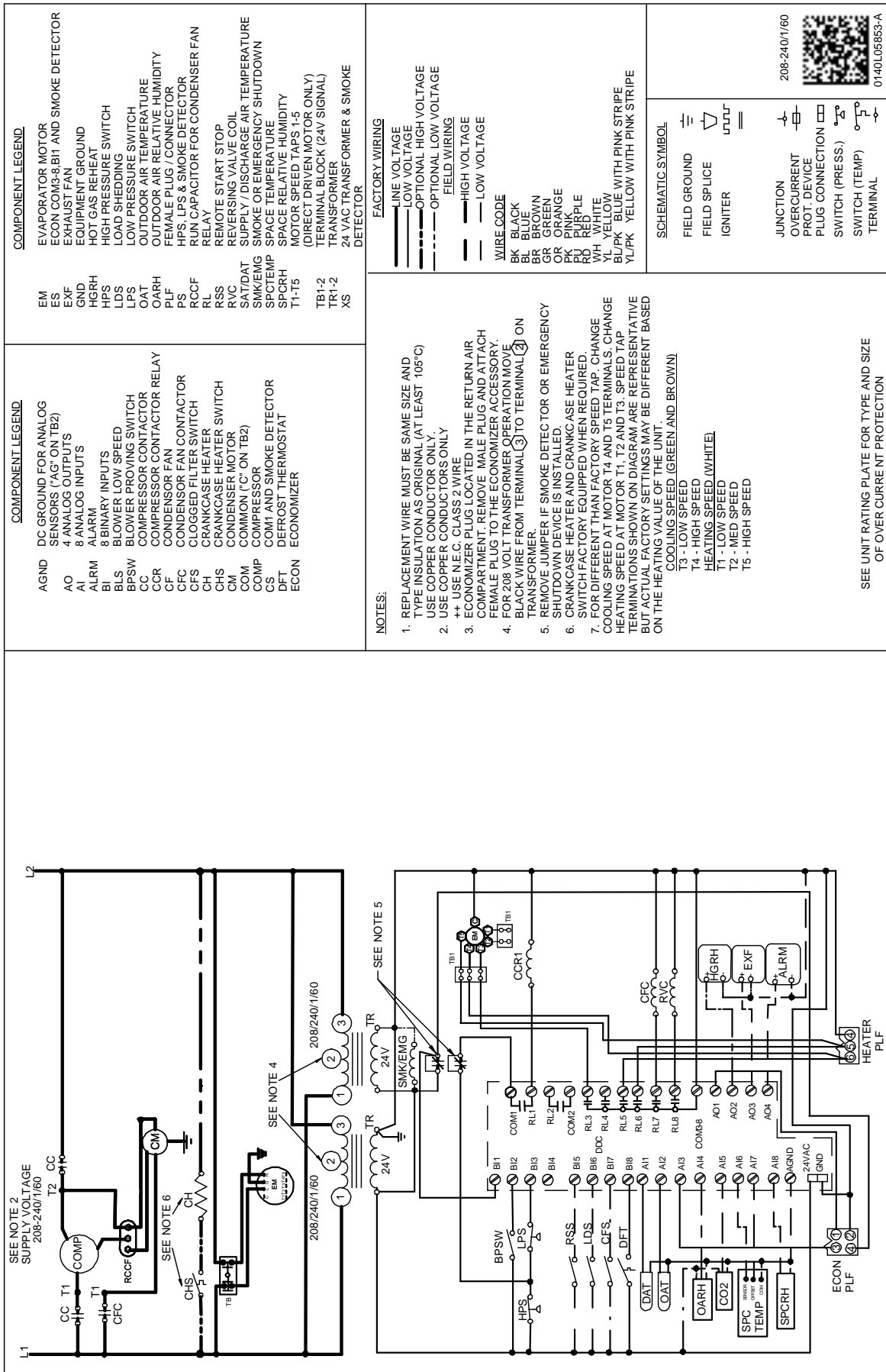

COMPONENT LEGEND	
EM	EVAPORATOR MOTOR
ES	ECON COMB-8 BIT AND SMOKE DETECTOR
EXF	EXHAUST FAN
GND	EQUIPMENT GROUND
HGRH	HOT GAS REHEAT
HPS	HIGH PRESSURE SWITCH
LDS	LOAD SHEDDING
LPS	LOW PRESSURE SWITCH
OAT	OUTDOOR AIR TEMPERATURE
OARH	OUTDOOR AIR RELATIVE HUMIDITY
PLF	FEMALE PLUG /CONNECTOR
PS	HPS, LPS & SMOKE DETECTOR
RCCF	RUN CAPACITOR FOR CONDENSER FAN RELAY
RL	REVERSE START STOP
RSS	REVERSING VALVE COIL
RVC	SUPPLY / DISCHARGE AIR TEMPERATURE
SAT/DAT	SMOKE OR EMERGENCY SHUTDOWN
SMK/EMG	SPACE TEMPERATURE
SPT/EMP	SPACE RELATIVE HUMIDITY
SPCRH	MOTOR SPEED TAPS 1-5
T1-T5	(DIRECT DRIVEN MOTOR ONLY)
TR1-2	TERMINAL BLOCK (24V SIGNAL)
TR1-2	TRANSFORMER
XS	24 VAC TRANSFORMER & SMOKE DETECTOR

COMPONENT LEGEND	
AGND	DC GROUND FOR ANALOG
AO	SENSORS ("AG" ON TB2)
AI	4 ANALOG OUTPUTS
ALRM	8 ANALOG INPUTS
ALRM	ALARM
BI	8 BINARY INPUTS
BLS	BLOWER LOW SPEED
BPSW	BLOWER PROVING SWITCH
CC	COMPRESSOR CONTACTOR
CCR	COMPRESSOR CONTACTOR RELAY
CF	CONDENSOR FAN
CFC	CONDENSOR FAN CONTACTOR
CFS	CLOGGED FILTER SWITCH
CH	CRANKCASE HEATER
CHS	CRANKCASE HEATER SWITCH
CM	COMMON MOTOR
COM	COMMON ("C" ON TB2)
COMP	COMPRESSOR
CS	COM1 AND SMOKE DETECTOR
DFT	DEFROST THERMOSTAT
ECON	ECONOMIZER

FACTORY WIRING	
—	LINE VOLTAGE
—	LOW VOLTAGE
—	OPTIONAL HIGH VOLTAGE
—	OPTIONAL LOW VOLTAGE
—	FIELD WIRING
—	HIGH VOLTAGE
—	LOW VOLTAGE

WIRE CODE	
BK	BLACK
BL	BLUE
BR	BROWN
GR	GREEN
OR	ORANGE
PK	PINK
PL	PURPLE
RD	RED
WH	WHITE
YL	YELLOW
YL/PK	YELLOW WITH PINK STRIPE
YL/BL	YELLOW WITH BLUE STRIPE

SCHEMATIC SYMBOL	
⊖	FIELD GROUND
⊕	FIELD SPLICE
⊖	IGNITER
⊖	JUNCTION
⊖	OVERCURRENT
⊖	PROT. DEVICE
⊖	PLUG CONNECTION
⊖	SWITCH (PRESS.)
⊖	SWITCH (TEMP)
⊖	TERMINAL

**NOTES:**

- REPLACEMENT WIRE MUST BE SAME SIZE AND TYPE INSULATION AS ORIGINAL (AT LEAST 105°C) USE COPPER CONDUCTOR ONLY.
- USE COPPER CONDUCTORS ONLY.
- ECONOMIZER PLUG LOCATED IN THE RETURN AIR COMPARTMENT. REMOVE MALE PLUG AND ATTACH FEMALE PLUG TO THE ECONOMIZER ACCESSORY.
- FOR 208 VOLT TRANSFORMER OPERATION MOVE BLACK WIRE FROM TERMINAL ② TO TERMINAL ③ ON TRANSFORMER.
- REMOVE JUMPER IF SMOKE DETECTOR OR EMERGENCY SHUTDOWN DEVICE IS INS TALLED.
- CRANKCASE HEATER AND CRANKCASE HEATER SWITCH FACTORY EQUIPPED WHEN REQUIRED.
- FOR DIFFERENT THAN FACTORY SPEED TAP. CHANGE COOLING SPEED AT MOTOR T4 AND T5 TERMINALS. CHANGE HEATING SPEED AT MOTOR T1, T2 AND T3. SPEED TAP TERMINATIONS SHOWN ON DIAGRAM ARE REPRESENTATIVE BUT ACTUAL FACTORY SETTINGS MAY BE DIFFERENT BASED ON THE HEATING VALUE OF THE UNIT.

COOLING SPEED (GREEN AND BROWN)	
T3	LOW SPEED
T4	HIGH SPEED
T5	MED SPEED

HEATING SPEED (WHITE)	
T1	LOW SPEED
T2	MED SPEED
T3	HIGH SPEED

SEE UNIT RATING PLATE FOR TYPE AND SIZE OF OVER CURRENT PROTECTION



Wiring is subject to change. Always refer to the wiring diagram on the unit for the most up-to-date wiring.

**WARNING**  
 HIGH VOLTAGE!  
 DISCONNECT ALL POWER BEFORE SERVICING OR INSTALLING THIS UNIT. MULTIPLE POWER SOURCES MAY BE PRESENT. FAILURE TO DO SO MAY CAUSE PROPERTY DAMAGE, PERSONAL INJURY OR DEATH.

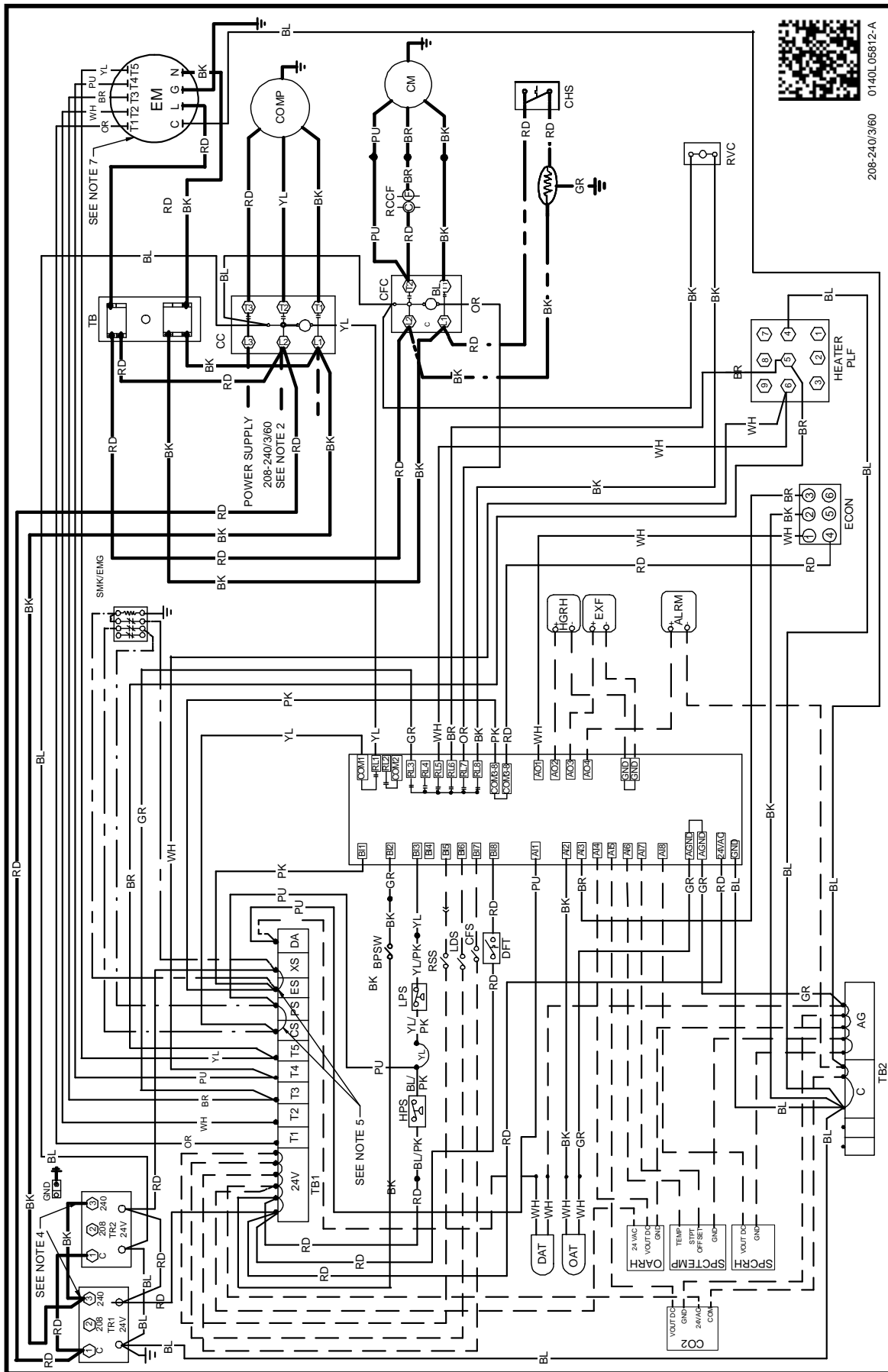

Wiring is subject to change. Always refer to the wiring diagram on the unit for the most up-to-date wiring.





**HIGH VOLTAGE!**  
**DISCONNECT ALL POWER BEFORE SERVICING OR INSTALLING THIS UNIT. MULTIPLE POWER SOURCES MAY BE PRESENT. FAILURE TO DO SO MAY CAUSE PROPERTY DAMAGE, PERSONAL INJURY OR DEATH.**

**WARNING**

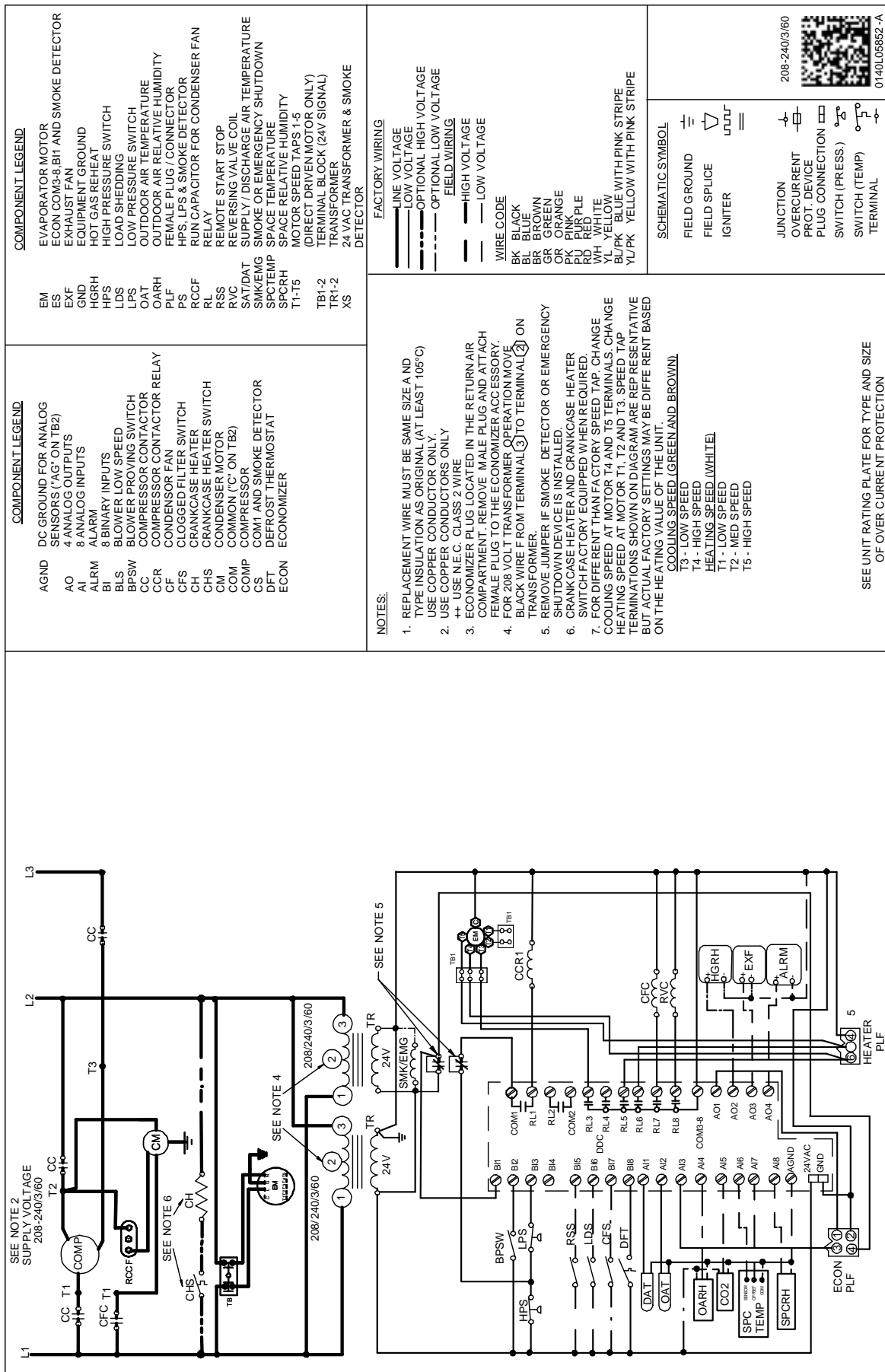

COMPONENT LEGEND	
EM	EVAPORATOR MOTOR
ES	ECON COMB-8 BIT AND SMOKE DETECTOR
EYF	EXHAUST FAN
GND	EQUIPMENT GROUND
HGRH	HOT GAS REHEAT SWITCH
HFS	HIGH PRESSURE SWITCH
LPS	LOW PRESSURE SWITCH
OARH	OUTDOOR AIR RELATIVE HUMIDITY FEMALE PLUG / CONNECTOR
PLF	HPS, LPS & SMOKE DETECTOR RUN CAPACITOR FOR CONDENSER FAN RELAY
PS	REMOTE START STOP
RCCF	REVERSING VALVE COIL
RL	SUPPLY / DISCHARGE AIR TEMPERATURE
RSS	SMOKE OR EMERGENCY SHUTDOWN
RVC	SPACE RELATIVE HUMIDITY
SATDAT	SPACE RELATIVE HUMIDITY
SMK/EMG	MOTOR SPEED TAPS 1-5 (DIRECT DRIVEN MOTOR ONLY)
SPCTEMP	TERMINAL BLOCK (24V SIGNAL)
SPCRH	TRANSFORMER
T1-T5	24 VAC TRANSFORMER & SMOKE DETECTOR
TB1-2	
TR1-2	
XS	

COMPONENT LEGEND	
AGND	DC GROUND FOR ANALOG
AO	4 ANALOG OUTPUTS
AI	8 ANALOG INPUTS
ALRM	ALARM
BI	8 BINARY INPUTS
BLS	BLOWER LOW SPEED
BPSW	BLOWER PROVING SWITCH
CCR	COMPRESSOR CONTACTOR RELAY
CFC	CONDENSER FAN
CHS	CLOGGED FILTER SWITCH
CH	CRANKCASE HEATER
CHS	CRANKCASE HEATER SWITCH
CM	CONDENSER MOTOR
COM	COMMON ('C' ON TB2)
COMP	COMPRESSOR
CS	COM1 AND SMOKE DETECTOR
DFT	DEFROST THERMOSTAT
ECON	ECONOMIZER

FACTORY WIRING	
—	LINE VOLTAGE
—	LOW VOLTAGE
—	OPTIONAL HIGH VOLTAGE
—	OPTIONAL LOW VOLTAGE
FIELD WIRING	
—	HIGH VOLTAGE
—	LOW VOLTAGE

WIRE CODE	
BK	BLACK
BL	BLUE
BR	BROWN
GR	GREEN
OR	ORANGE
PK	PINK
PL	PURPLE
RD	RED
WH	WHITE
YL	YELLOW
BL/PK	BLUE WITH PINK STRIPE
YL/PK	YELLOW WITH PINK STRIPE

SCHEMATIC SYMBOL	
⊖	FIELD GROUND
∇	FIELD SPLICE
⊕	IGNITER
⊖	JUNCTION
⊖	OVERCURRENT PROT. DEVICE
⊖	PLUG CONNECTION
⊖	SWITCH (PRESS)
⊖	SWITCH (TEMP)
⊖	TERMINAL

208-240/3/60

0140L05852-A

**NOTES:**

- REPLACEMENT WIRE MUST BE SAME SIZE AND TYPE INSULATION AS ORIGINAL (AT LEAST 105°C) USE COPPER CONDUCTOR ONLY.
- USE COPPER CONDUCTORS ONLY.
- ECONOMIZER PLUG LOCATED IN THE RETURN AIR COMPARTMENT. REMOVE MALE PLUG AND ATTACH FEMALE PLUG TO THE ECONOMIZER ACCESSORY.
- FOR 208 VOLT TRANSFORMER OPERATION MOVE BLACK WIRE FROM TERMINAL ③ TO TERMINAL ② ON TRANSFORMER.
- REMOVE JUMPER IF SMOKE DETECTOR OR EMERGENCY SHUTDOWN DEVICE IS INSTALLED.
- CRANKCASE HEATER AND CRANKCASE HEATER SWITCH FACTORY EQUIPPED WHEN REQUIRED.
- FOR DIFFERENT THAN FACTORY SPEED TAP, CHANGE COOLING SPEED AT MOTOR T4 AND T5 TERMINALS. CHANGE HEATING SPEED AT MOTOR T1, T2 AND T3. SPEED TAP TERMINATIONS SHOWN ON DIAGRAM ARE REPRESENTATIVE BUT ACTUAL FACTORY SETTINGS MAY BE DIFFERENT BASED ON THE HEATING VALUE OF THE UNIT.

COOLING SPEED (GREEN AND BROWN)  
 T3 - LOW SPEED  
 T4 - HIGH SPEED  
 HEATING SPEED (WHITE)  
 T1 - LOW SPEED  
 T2 - MED SPEED  
 T5 - HIGH SPEED

SEE UNIT RATING PLATE FOR TYPE AND SIZE OF OVER CURRENT PROTECTION

Wiring is subject to change. Always refer to the wiring diagram on the unit for the most up-to-date wiring.



# Start-up Checklist

*\*Store in job file*

Date: \_\_\_\_\_ Location: \_\_\_\_\_  
Model Number: \_\_\_\_\_  
Serial Number: \_\_\_\_\_  
Technician: \_\_\_\_\_ Unit #: \_\_\_\_\_

## Pre Start-Up

*(Check each item as completed)*

- Verify all packaging material has been removed.
- Remove all shipping brackets per installation instructions.
- Verify the job site voltage agrees with the unit serial plate.
- Verify condensate connection is installed per installation instructions.
- Verify proper clearance around the unit for safety, service, maintenance and proper unit operation.
- Verify proper weatherproofing of all ductwork, roof curbs and electrical connections.
- Check that the flue screen is in place.
- Check gas piping for leaks.
- Verify gas pressure to the unit is within the range specified on the serial plate.
- Check to ensure that all fans, pulleys and wheels are secure.
- Check for proper belt tension and alignment per installation instructions.
- Check refrigerant piping for rubbing and leaks. *Repair if necessary.*
- Check unit wiring to ensure it is not in contact with refrigerant piping or sharp metal edges.
- Check all electrical connections and terminals. *Tighten as needed.*
- Verify that the crankcase heaters have been energized for 24 hours.
- Verify the scroll compressor(s) are rotating in the right direction.
- Verify all accessories are installed and operating correctly.
- Check filters and replace if necessary.
- Verify the installation of the thermostat.



# Start-up Checklist

**Start-Up**  
*(Insert the values as each item is completed.)*

## ELECTRICAL

Supply Voltage	L1 - L2	_____	L2 - L3	_____	L3 - L1	_____
Circuit 1 Compressor Amps	L1	_____	L2	_____	L3	_____
Circuit 2 Compressor Amps	L1	_____	L2	_____	L3	_____
Blower Amps	L1	_____	L2	_____	L3	_____
Condenser Fan Amps	Fan 1	_____	Fan 2	_____	Fan 3	_____

## BLOWER EXTERNAL STATIC PRESSURE

Return Air Static Pressure	_____	IN. W.C.
Supply Air Static Pressure	_____	IN. W.C.
Total External Static Pressure	_____	IN. W.C.
Blower Wheel RPM	_____	RPM

## TEMPERATURES

Outdoor Air Temperature	_____	DB	_____	WB
Return Air Temperature	_____	DB	_____	WB
Cooling Supply Air Temperature	_____	DB	_____	WB
Heating Supply Air Temperature	_____	DB	_____	

## PRESSURES

Gas Inlet Pressure	_____	IN. W.C.		
Gas Manifold Pressure	_____	IN. W.C. (Low Fire)	_____	IN. W.C. (High Fire)
Suction Circuit 1	_____	PSIG	_____	°F
Superheat (Orifice System)			_____	°F
Suction Circuit 2	_____	PSIG	_____	°F
Superheat (Orifice System)			_____	°F
Discharge Circuit 1	_____	PSIG	_____	°F
Subcooling (TXV System)			_____	°F
Discharge Circuit 2	_____	PSIG	_____	°F
Subcooling (TXV System)			_____	°F

## (HEAT PUMP ONLY)

Suction Circuit 1	_____	PSIG	_____	°F
Suction Circuit 2	_____	PSIG	_____	°F
Discharge Circuit 1	_____	PSIG	_____	°F
Discharge Circuit 2	_____	PSIG	_____	°F

**NOTE:** Refer to IOD-7006 included in the literature pack for installing horizontal duct covers.

© 2015 - 2017 **DAIKIN COMPANY, L.P.**

- Products
- Parts
- Warranties
- Contractor Programs and Training
- Customer Services
- Finance Options

Visit our website at [www.daikinac.com](http://www.daikinac.com)